



优材 佳意 精工 美境
HIGH QUALITY,
WELL DESIGN, EXQUISITE CRAFT,
BEAUTIFUL EFFECT.

POOL MOSAIC TILES CATALOGUE

2023/2024

泳池陶瓷马赛克产品手册



创立 **FOUNDED SINCE 1988**

“彩花”品牌于1988年创立于广东佛山，该品牌属于佛山市石湾裕龙陶瓷有限公司。自创立伊始就秉承“不断提升制造能力，制作陶瓷精品”的理念，为客户提供优质的产品与服务。
 "Caihua" brand was founded in Foshan, Guangdong in 1988. It belongs to FOSHAN SHIWAN YULONG CERAMIC CO., LTD. Since its inception, it has been adhering to the concept of "continuously improving manufacturing capabilities and producing fine ceramics" to provide customers with high-quality products and services.

创新 **INNOVATION**

彩花极其注重产品升级及制造工艺能力的提升。公司在建筑装饰陶瓷领域推出多种新品类，并率先在本行业引进国外先进的生产技术、生产设备，同时在生产经营过程中不断进行技术革新，将多种先进的新型工艺应用于本行业，不断创新，获得了多个行业专利。
 Caihua attaches great importance to product upgrades and the improvement of manufacturing process capabilities. The company has launched a variety of new products in the field of architectural decoration ceramics, and has taken the lead in introducing advanced foreign production technology and equipment in the industry. At the same time, it has continuously carried out technological innovations and applied a variety of advanced new technologies to the industry in the production and operation process; keep constantly innovating and have obtained several industry patents.

专注 **FOCUS**

1999年，彩花专注于陶瓷镶嵌锦砖制造领域。凭借强大的产品研发设计能力和多年丰富的生产经验，自主生产的陶瓷镶嵌锦砖兼具镶嵌锦砖独有的装饰艺术美感与优秀的产品品质，成功打入五大洲多个国家市场，引领业界产品发展方向。
 Caihua has focused on the manufacture of ceramic mosaic tiles since 1999. With strong product R&D and design capabilities and many years of rich production experience, we have manufactured ceramic mosaic tiles with the unique decorative artistic beauty and excellent product quality, and successfully sold in the markets of multiple countries on five continents, leading the development direction of the industry.

责任 **RESPONSIBILITY**

公司具有极强的社会责任感，是佛山首家污水零排放的陶瓷企业，同时也是佛山首批通过清洁生产标准审核的陶瓷企业。
 The company has a strong sense of social responsibility. It is the first ceramic enterprise in Foshan who realize zero discharge of production sewage, and it is also the first batch of ceramic enterprise in Foshan to pass the clean production standard audit.

奋进 **AMBITION**

2021年，彩花结合市场变化，基于原有的陶瓷镶嵌锦砖制作基础，调整研发、制造、营销等经营模式，引进国外优秀的镶嵌锦砖品牌与产品，以“艺术、人文、设计”为核心服务理念，助力客户构建极具镶嵌之美的艺术生活空间。
 In 2021, based on the original ceramic mosaic tile production technology, considering the change of market conditions, Caihua will adjust the business model of R&D, manufacturing and marketing; import excellent foreign mosaic tile brands and products; with "art, humanities, and design" as the core of service concept, help customers build an artistic living space with great mosaic beauty.



▲ 中国陶瓷城展厅A313 CAIHUA showroom in China Ceramic City



▲ 总部营销中心 CAIHUA Headquarter Marketing Center

Contents

目录

彩花马赛克采用绿色环保、无辐射原材料生产，防滑耐磨性能极佳，被广泛用于厨房、卫生间等防滑耐磨性能要求高的地方。

除了具有较强的实用性能外，彩花马赛克规格多样、造型优美、颜色丰富、纹理和效果灵活多变，具有更强的艺术表现力，是空间个性化的时装，不断地满足广大设计师和消费者的各种需求，而且不断地展示其高技术和风格上的价值。

CAIHUA MOSAIC is made with green cleaning raw materials without radiation, and it is widely used for the decoration in the kitchen and bathroom at home because of its great performance of slip resistance and abrasive resistance. Besides its functional performance, CAIHUA MOSAIC has always strongly showed artistic expression to the designer and the user with its various size, shape, colors, texture and finished. And CAIHUA MOSAIC is constantly demonstrating to the creation of mosaics with high technical and stylistic value.



泳池马赛克 POOL MOSAIC TILES

- 01 加勒比海系列 / CARIBBEAN SERIES
- 09 海天之恋系列 / SEA OF LOVE SERIES
- 12 科尔托纳系列 / CORTONA SERIES
- 13 碧海蓝天系列 / BH SERIES
- 19 冰山雪莲系列 / HBP SERIES
- 23 青山绿水系列 / GREEN SERIES
- 24 拼花装饰线系列 / WATER LINES
- 25 泳池配件 / TRIMS & CORNERS
- 27 设计案例 / DESIGN CASES
- 29 工程案例 / PROJECT CASES
- 35 产品资讯 / PRODUCTS INFORMATION
- 35 马赛克的施工方法说明 / MOSAICS INSTALLATION



POOL MOSAIC TILES,

泳池马赛克

Caihua



加勒比海系列 CARIBBEAN SERIES

产品信息 / Product information

单粒规格 / Chip Size: 23X23mm
联长尺寸 / Sheet size: 300X300mm (含缝 / included joints)

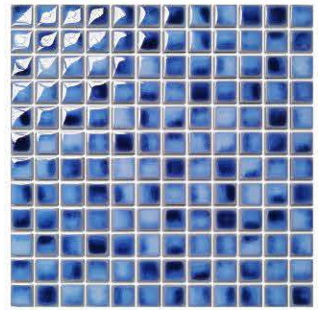

NEW BHX08270 (glossy)

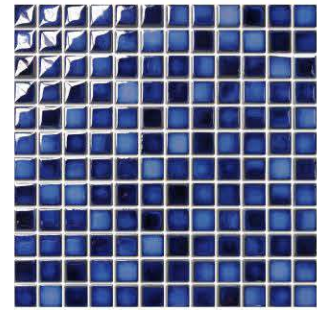

NEW BHX08250 (glossy)

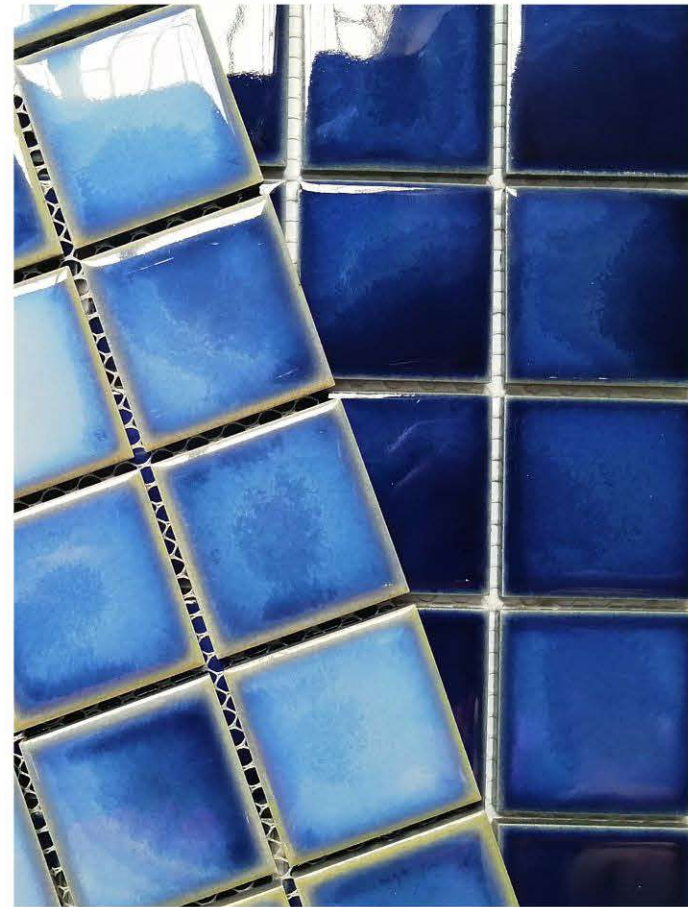

产品信息 / Product information

单粒规格 / Chip Size: 48X48mm
联长尺寸 / Sheet size: 306X306mm (含缝 / included joints)



NEW BHP08270 (glossy)

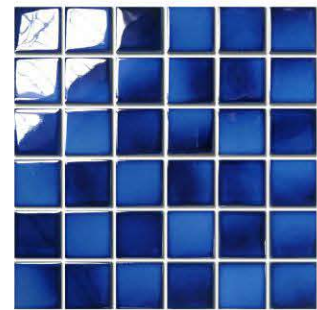

NEW BHP08250 (glossy)



产品信息 / Product information

单粒规格 / Chip Size: 48X48mm
联长尺寸 / Sheet size: 306X306mm (含缝 / included joints)

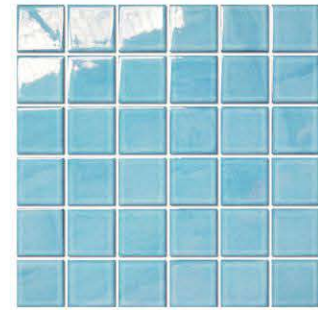

NEW MPTR8064 (glossy)

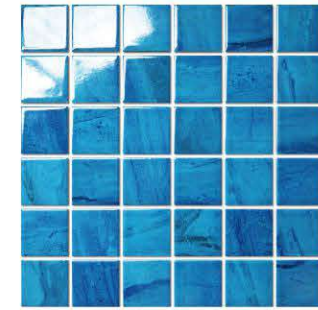

NEW MPTR8066 (glossy)

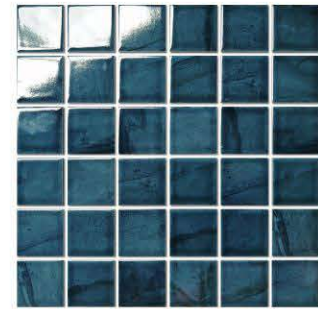
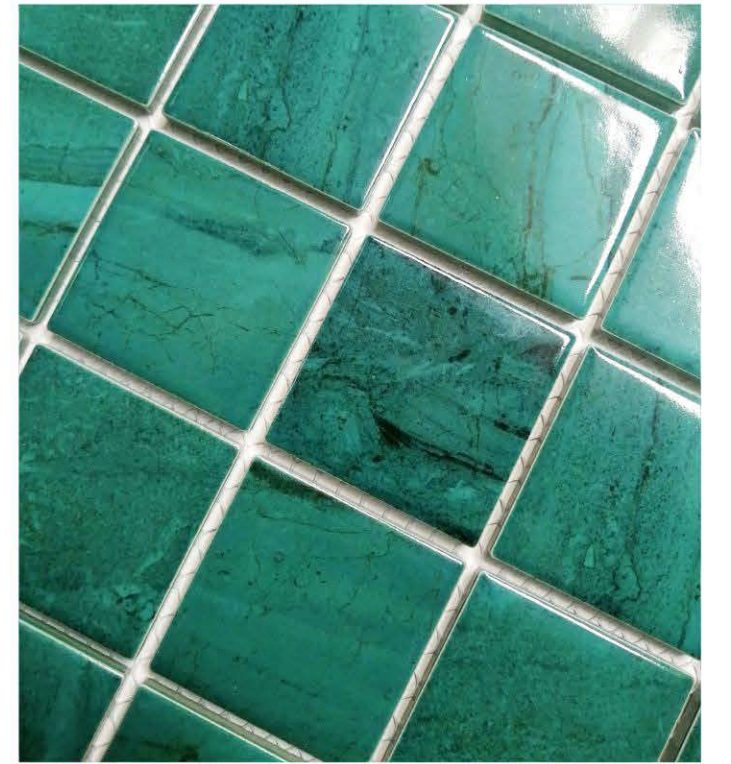

NEW MPTR8068 (glossy)

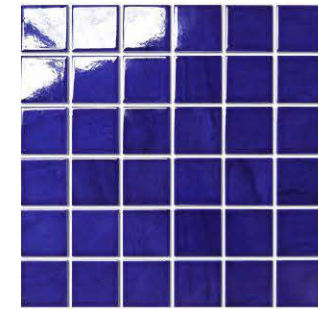

NEW MPTR8070 (glossy)



NEW MPTR6062 (glossy)

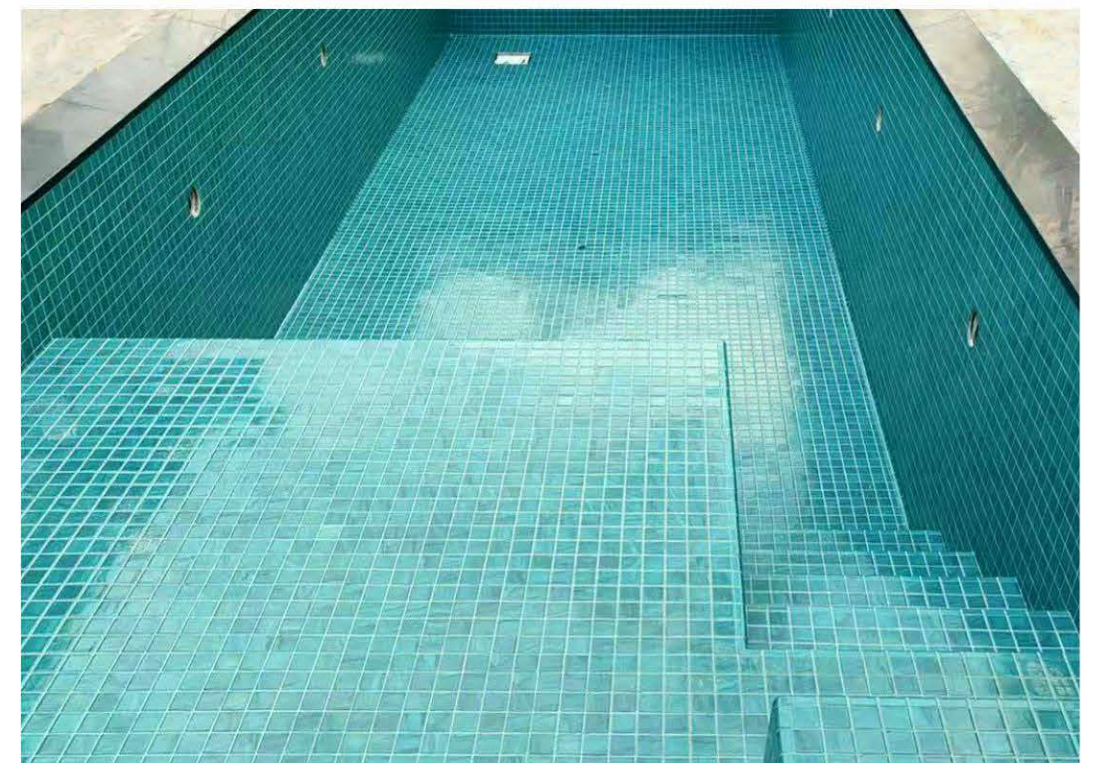

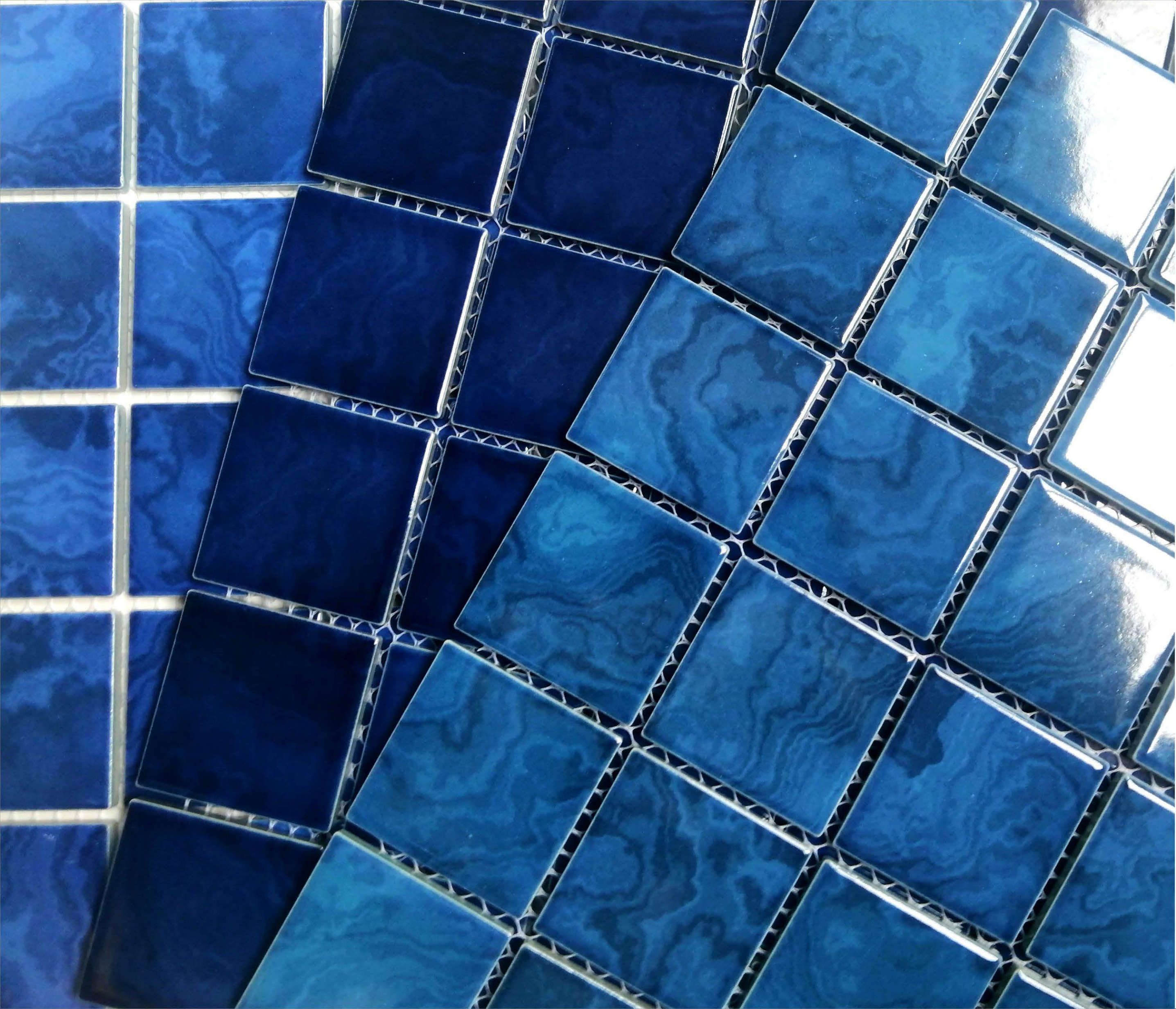

加勒比海系列 CARIBBEAN SERIES

产品信息 / Product information

单粒规格 / Chip Size: 48X48mm

联长尺寸 / Sheet size: 306X306mm (含缝 / included joints)

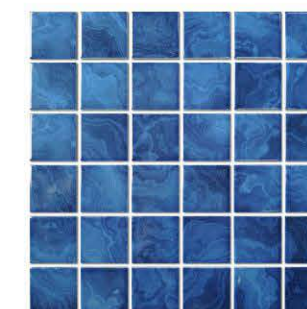

NEW MPTS98071 (glossy)

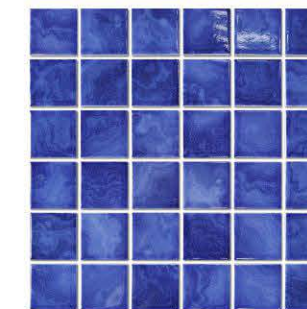

NEW MPTS98072 (glossy)

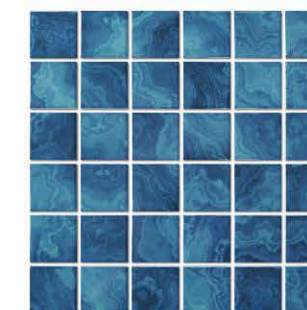

NEW MPTS98073 (glossy)



NEW MPTS98074 (glossy)

加勒比海系列 CARIBBEAN SERIES

产品信息 / Product information

单粒规格 / Chip Size: 73X73mm
联长尺寸 / Sheet size: 306X306mm (含缝 / included joints)

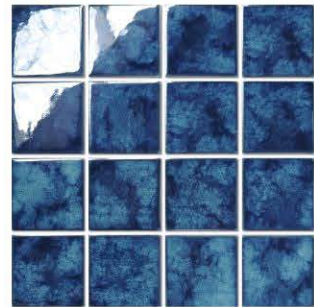

NEW PHF08306 (glossy)

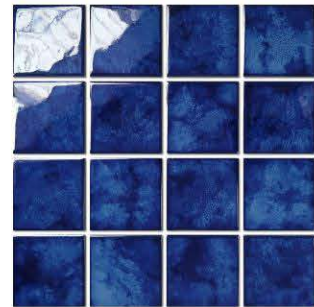

NEW PHF08308 (glossy)



NEW PHFFG08306 (glossy)



NEW PHFFG08308 (glossy)

产品信息 / Product information

单粒规格 / Chip Size: 48X48mm
联长尺寸 / Sheet size: 306X306mm (含缝 / included joints)

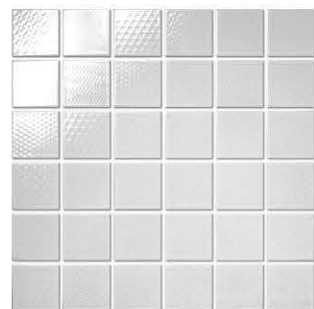

NEW HP6470MH (glossy)

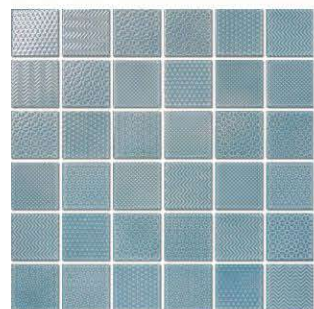

NEW BHP08282MH (glossy)

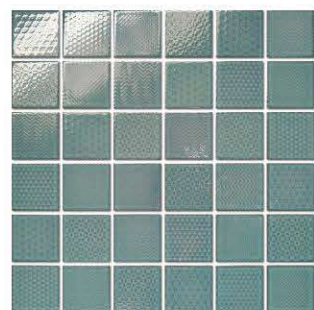

NEW BHP06152MH (glossy)



NEW BHP08280MH (glossy)



NEW HP02032MH (glossy)

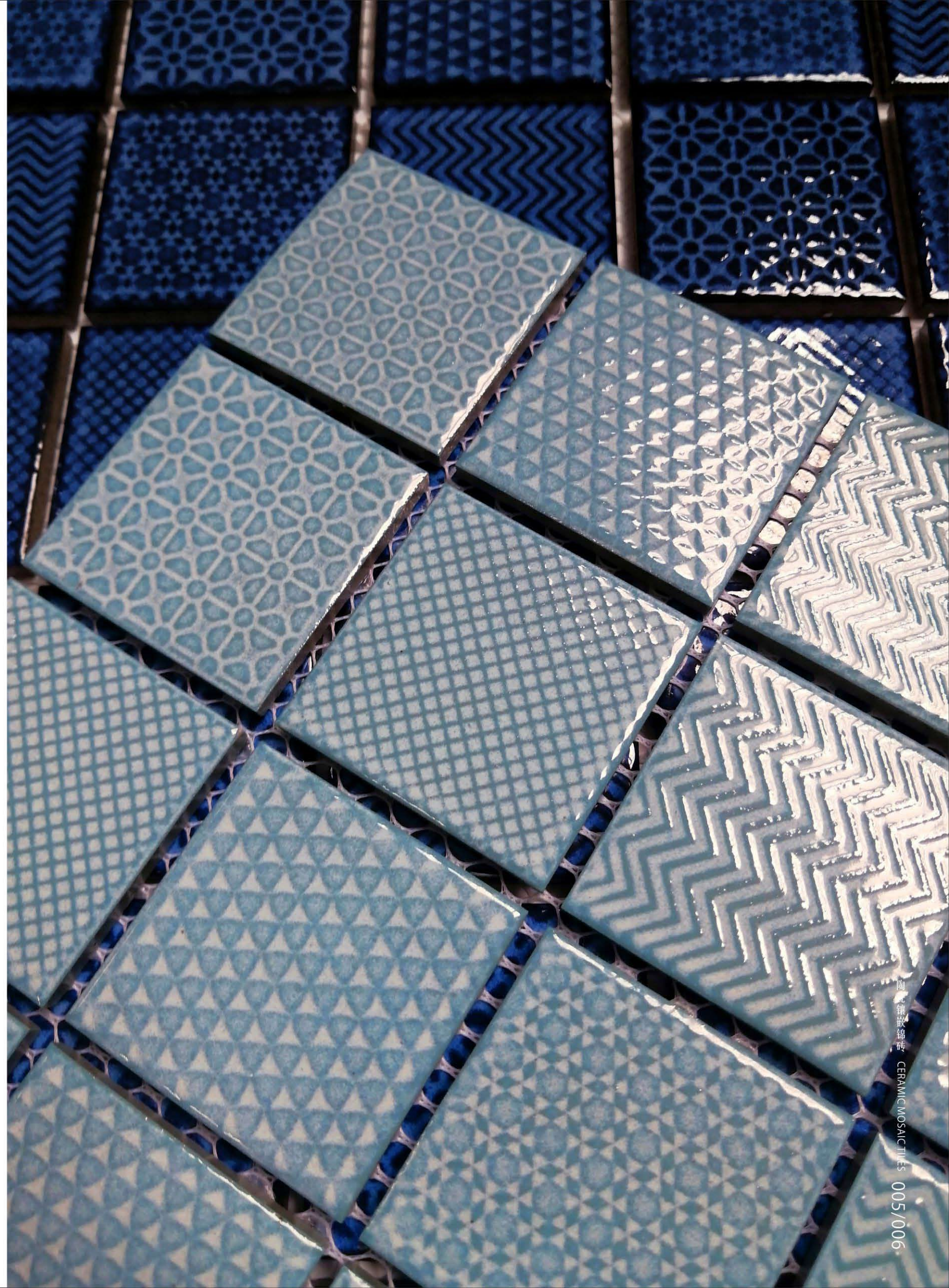
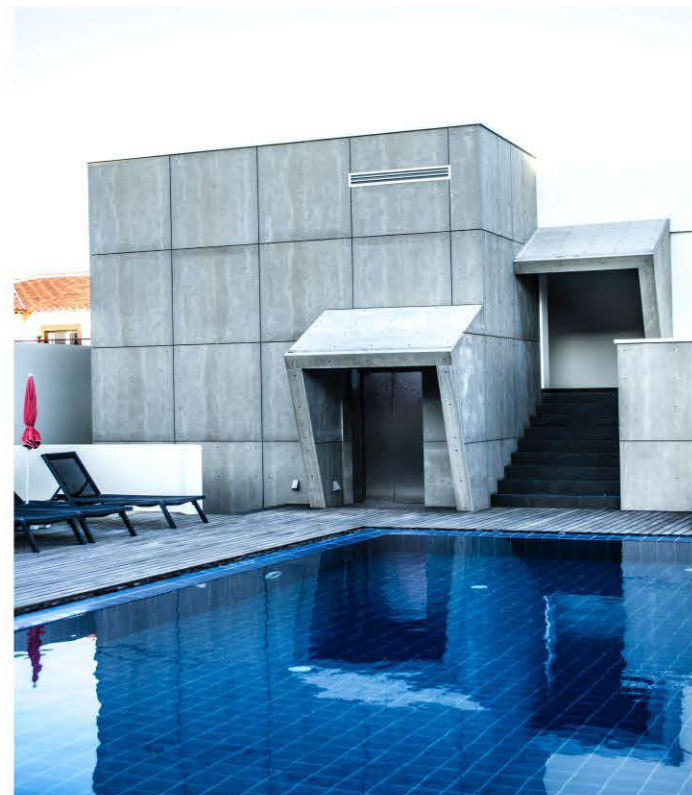

加勒比海系列 CARIBBEAN SERIES

产品信息 / Product information

单粒规格 / Chip Size: 48X48mm
联长尺寸 / Sheet size: 306X306mm (含缝 / included joints)

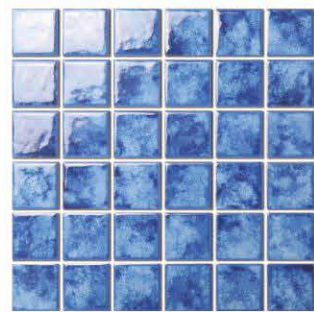

PHP08216 (glossy)

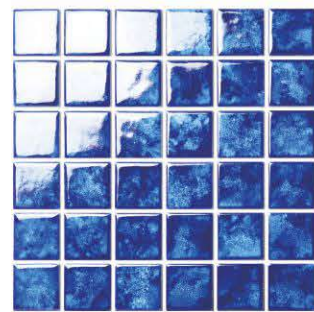

PHP08218 (glossy)

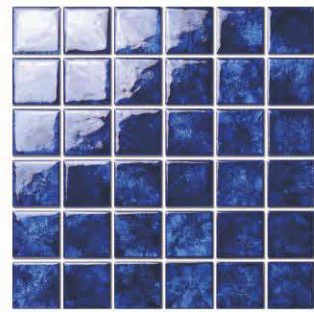

PHP08220 (glossy)



产品信息 / Product information

单粒规格 / Chip Size: 73X73mm
联长尺寸 / Sheet size: 306X306mm (含缝 / included joints)

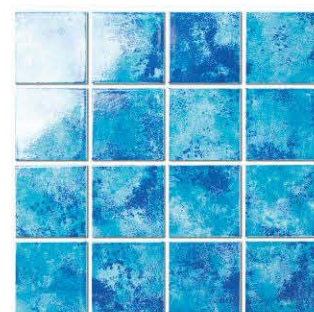

PHF08196 (glossy)

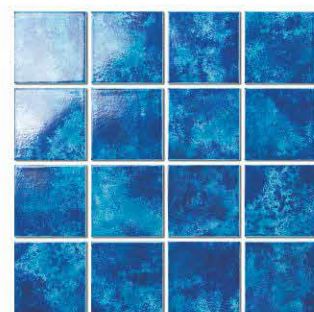

PHF08198 (glossy)

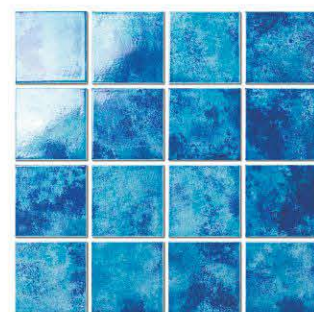

PHF001M (glossy)



海天之恋系列 SEA OF LOVE SERIES

产品信息 / Product information

单粒规格 / Chip Size: 48X48mm
联长尺寸 / Sheet size: 306X306mm (含缝 / included joints)

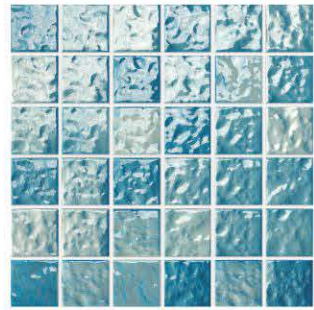

HTP08012 (glossy)

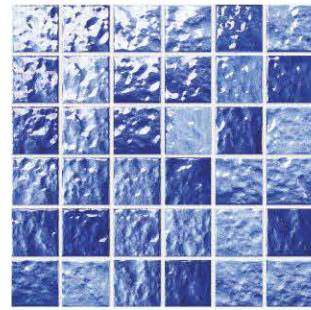

HTP08014 (glossy)

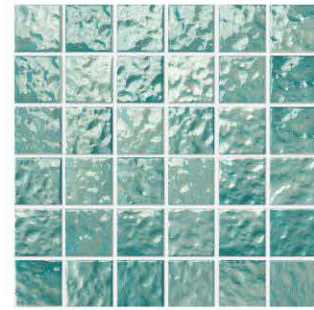

HTP06012 (glossy)

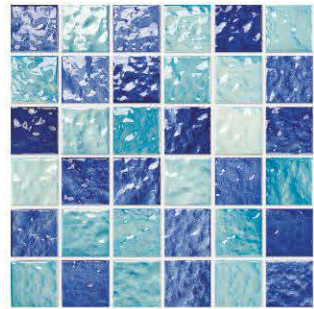

HTP001M (glossy)

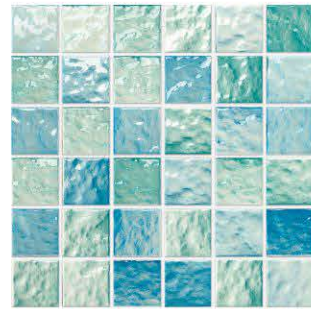

HTP002M (glossy)



HTP08014
50%

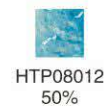

HTP08012
50%



HTP08012
50%



HTP06012
50%

产品信息 / Product information

单粒规格 / Chip Size: 95X95mm
联长尺寸 / Sheet size: 295.5X295.5mm (含缝 / included joints)



HN6470T (glossy)



HN08012T (glossy)

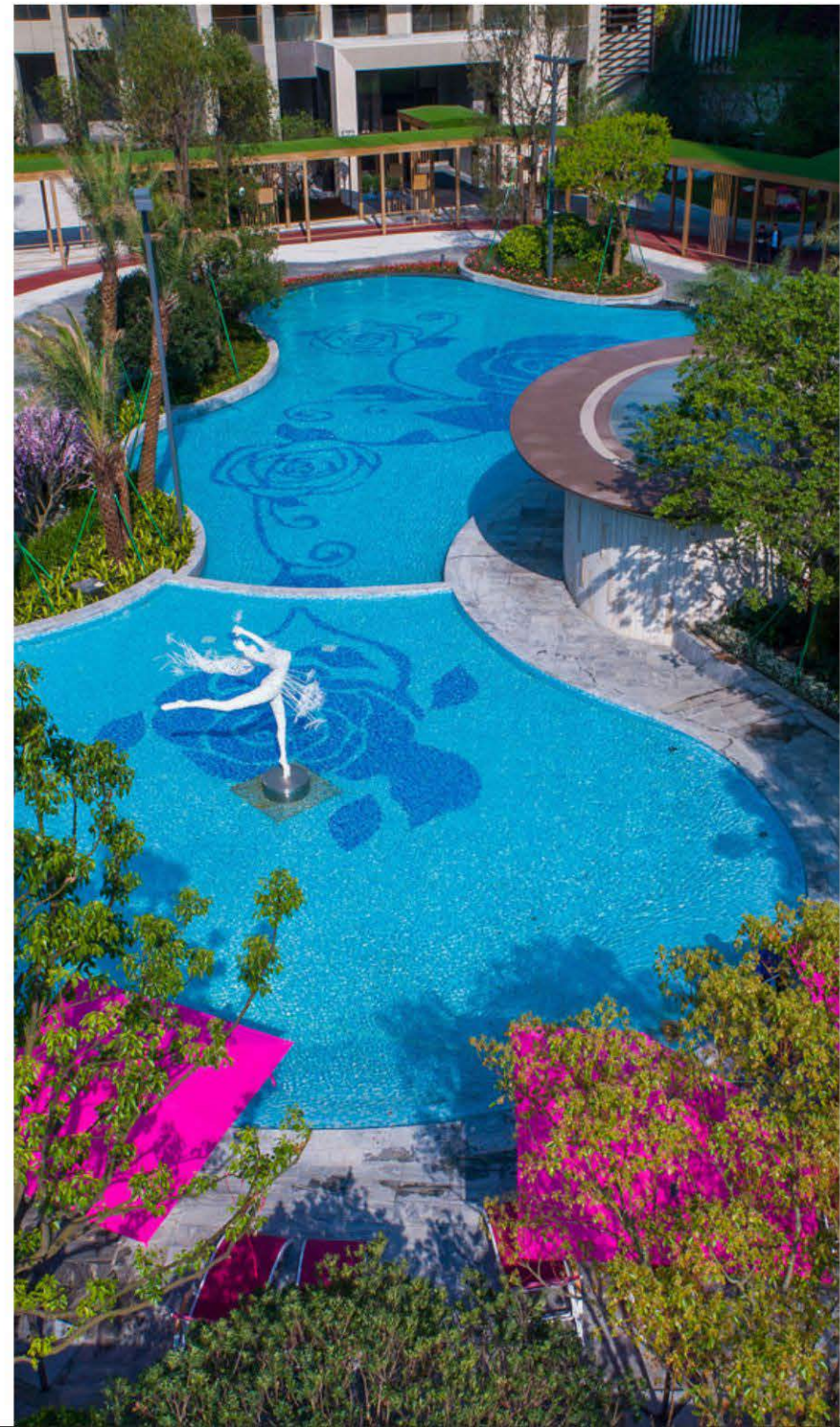

产品信息 / Product information

单粒规格 / Chip Size: 95X95mm
联长尺寸 / Sheet size: 295.5X295.5mm (含缝 / included joints)

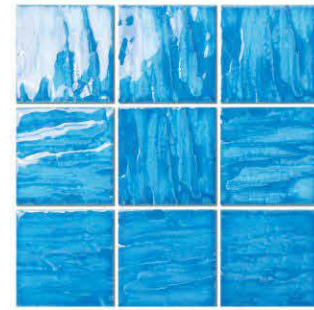

BHN08162 (glossy)

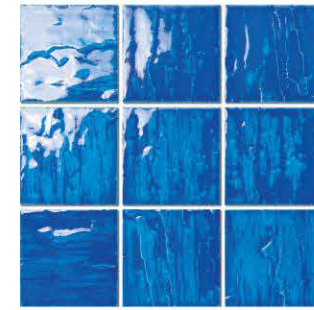

BHN08164 (glossy)



BHN08166 (glossy)



BHN08168 (glossy)

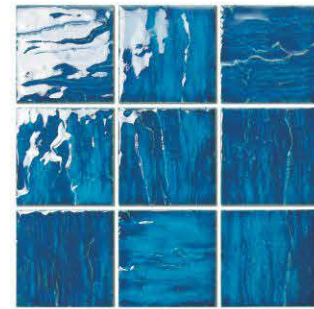

BHN08170 (glossy)

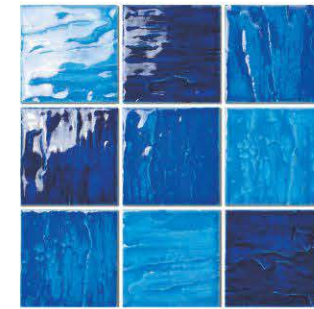

BHN001M (glossy)

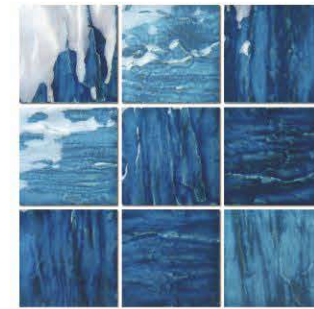

BHN005M (glossy)

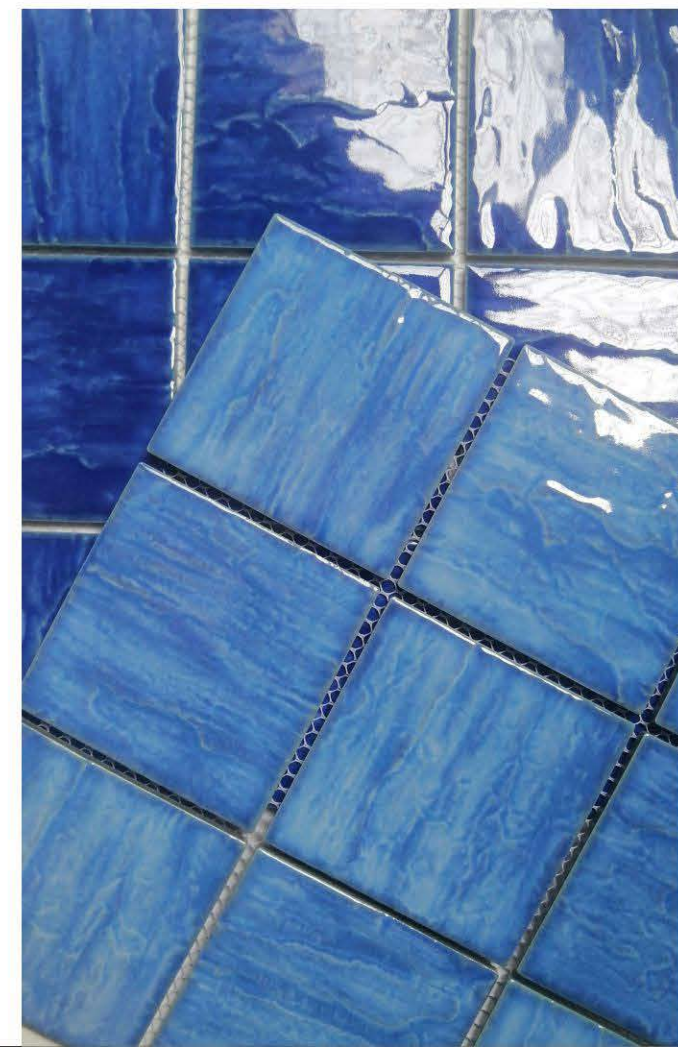

海天之恋系列 SEA OF LOVE SERIES

产品信息 / Product information

单粒规格 / Chip Size: 48X48mm
联长尺寸 / Sheet size: 306X306mm (含缝 / included joints)



NEW MPYN2028 (matt)



NEW MPYN2029 (matt)



NEW MPYN8001 (matt)



NEW MPYN6001 (matt)

产品信息 / Product information

单粒规格 / Chip Size: 95X95mm
联长尺寸 / Sheet size: 295.5X295.5mm (含缝 / included joints)



NEW MNYN2028 (matt)



NEW MNYN2029 (matt)



NEW MNYN8001 (matt)

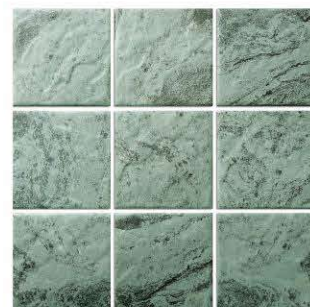

NEW MNYN6001 (matt)

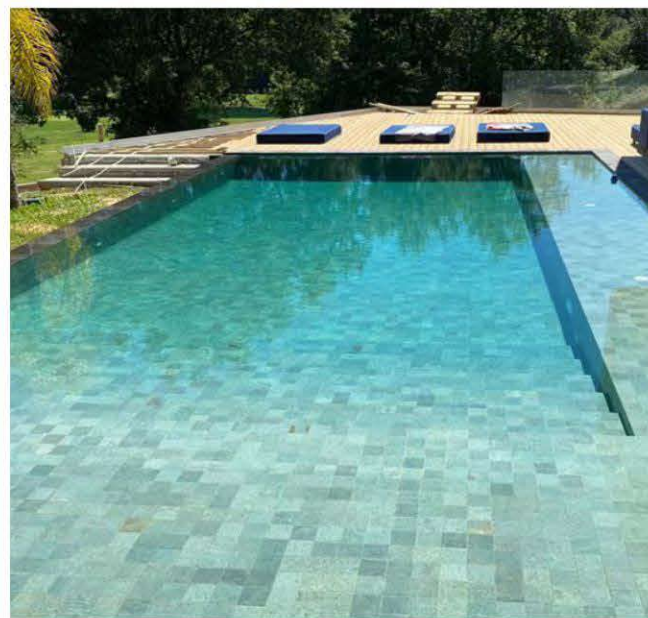
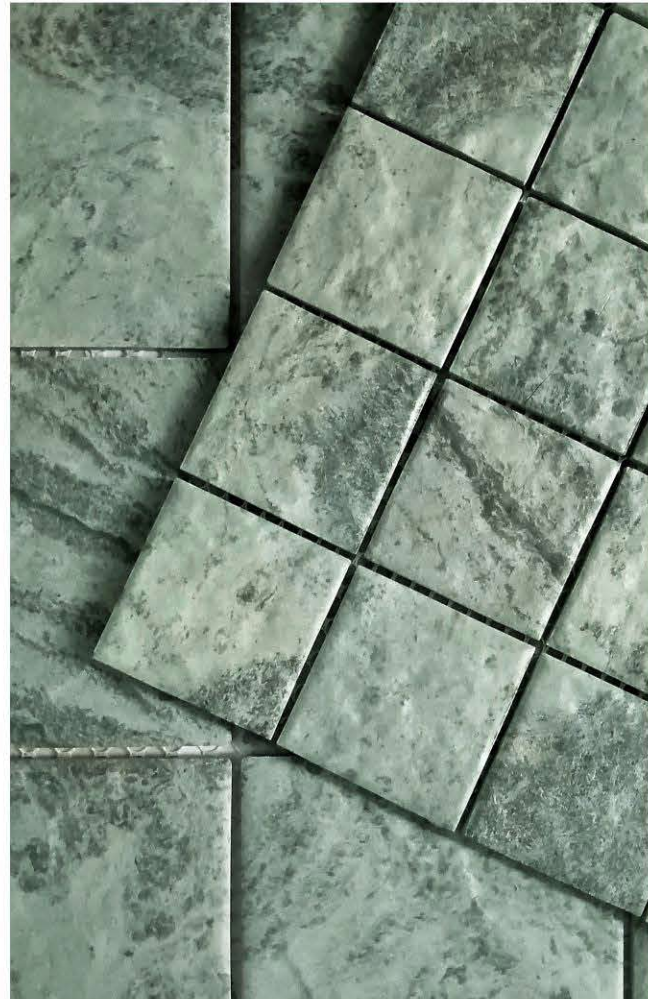

海天之恋系列 SEA OF LOVE SERIES

产品信息 / Product information

单粒规格 / Chip Size: 73X73mm
联长尺寸 / Sheet size: 306X306mm (含缝 / included joints)

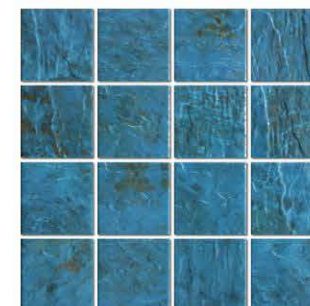

MFHT6002 (glossy)

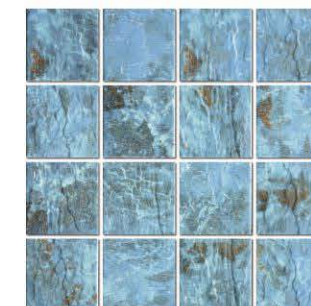

MFHT6004 (glossy)

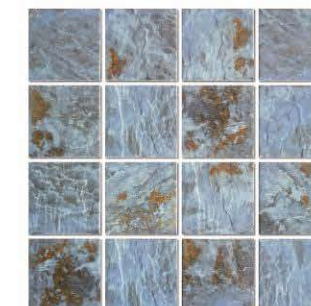

MFHT8002 (glossy)

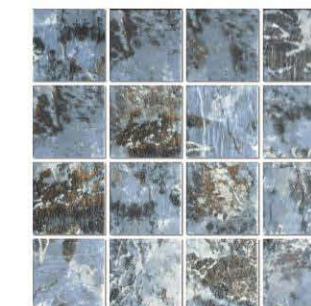

MFHT8004 (glossy)

科尔托纳系列 CORTONA SERIES

产品信息 / Product information

单粒规格 / Chip Size: 48X48mm
联长尺寸 / Sheet size: 306X306mm (含缝 / included joints)



MPSD9005 (matt)



MPSD2009 (matt)



MPSD2011 (matt)



MPSD2013 (matt)



碧海蓝天系列 BH SERIES

产品信息 / Product information

单粒规格 / Chip Size: 23X23mm
联长尺寸 / Sheet size: 300X300mm (含缝 / included joints)



BFX512M (glossy)

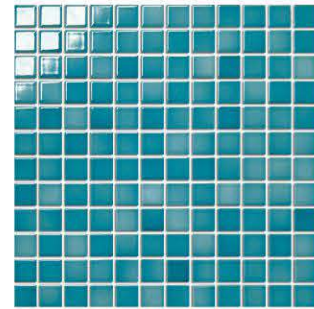

NEW HX08214 (glossy)



NEW BFX602 (glossy)

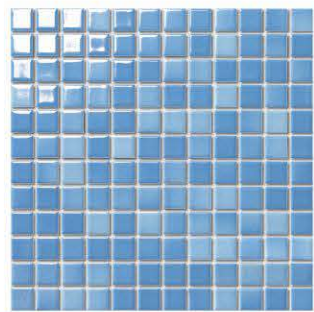

HX23999 (glossy)

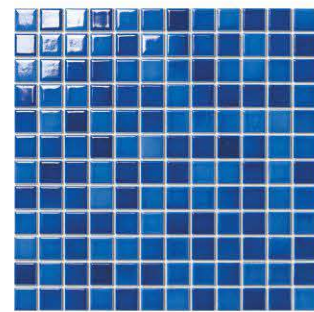

HX23998 (glossy)

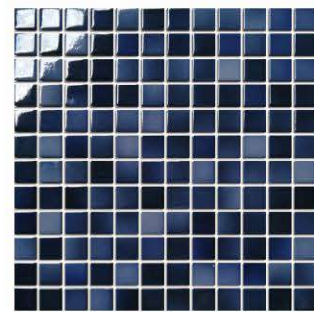

BFX5122 (glossy)

产品信息 / Product information

单粒规格 / Chip Size: 23X23mm
联长尺寸 / Sheet size: 300X300mm (含缝 / included joints)

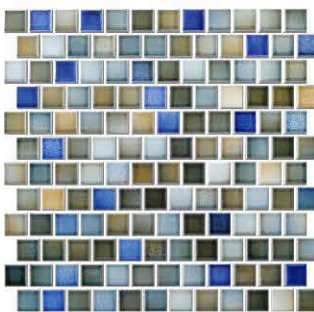

BFX512MGA (glossy)

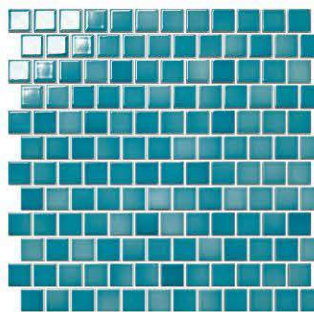

NEW HX08214GA (glossy)



NEW BFX602GA (glossy)

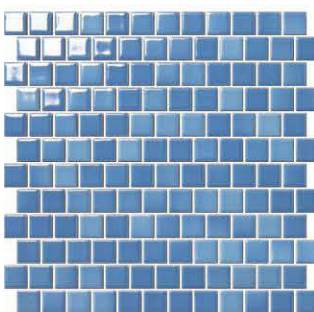

HX23999GA (glossy)

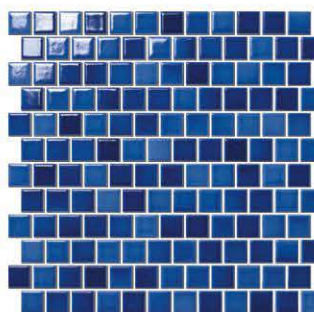

HX23998GA (glossy)



BFX5122GA (glossy)

产品信息 / Product information

单粒规格 / Chip Size: 48X48mm
联长尺寸 / Sheet size: 306X306mm (含缝 / included joints)



NEW BHP08310 (glossy)



NEW BHP08316 (glossy)



BHP02138 (glossy)



HP02032 (glossy)

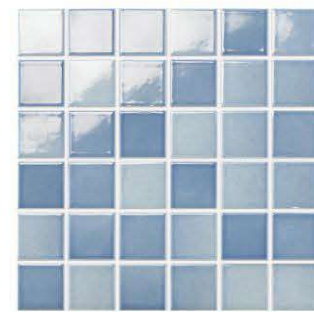

HP23999 (glossy)

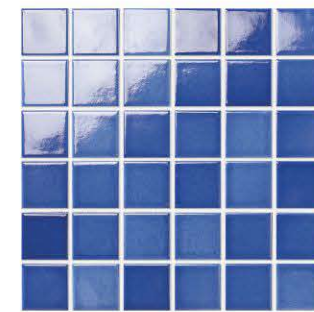

HP23998 (glossy)

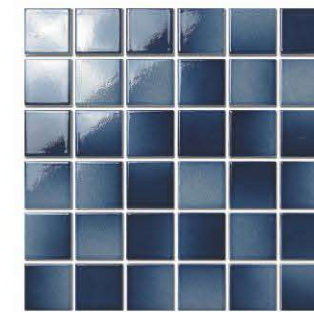

HP23995 (glossy)

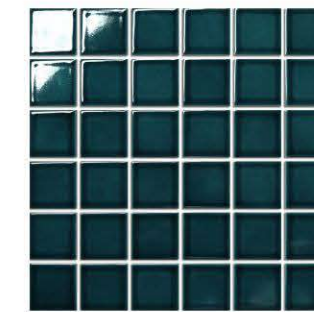

BHP08206 (glossy)

产品信息 / Product information

单粒规格 / Chip Size: 48X48mm
联长尺寸 / Sheet size: 306X306mm (含缝 / included joints)



NEW BHP08310GA (glossy)



NEW BHP08316GA (glossy)



BHP02138GA (glossy)



HP02032GA (glossy)

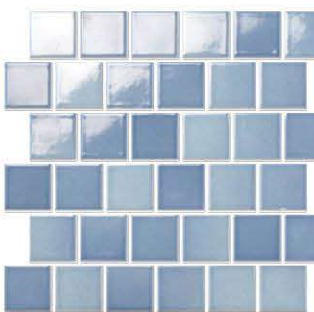

HP23999GA (glossy)

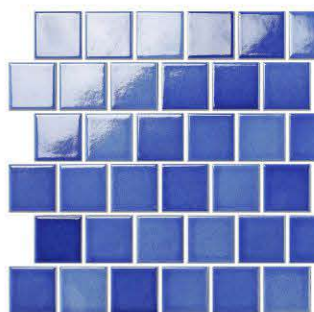

HP23998GA (glossy)



HP23995GA (glossy)

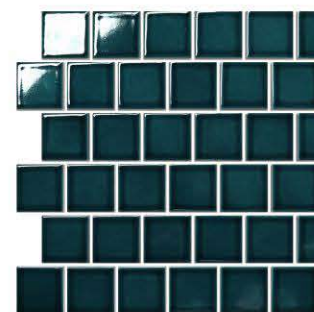

BHP08206GA (glossy)

碧海蓝天系列 BH SERIES

产品信息 / Product information

单粒规格 / Chip Size: 48X48mm

联长尺寸 / Sheet size: 306X306mm (含缝 / included joints)

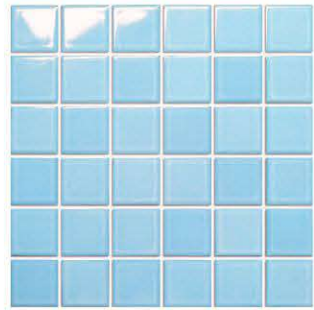

BHP08202 (glossy)

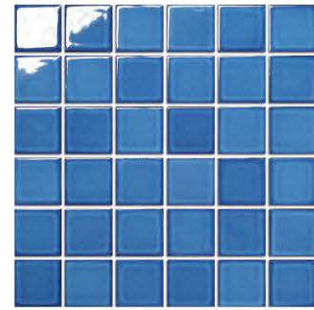

BHP08210 (glossy)

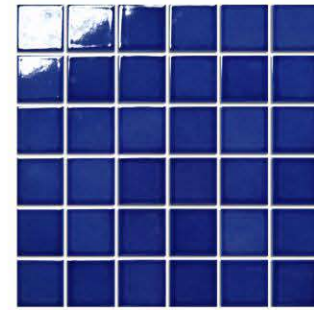

BHP08208 (glossy)

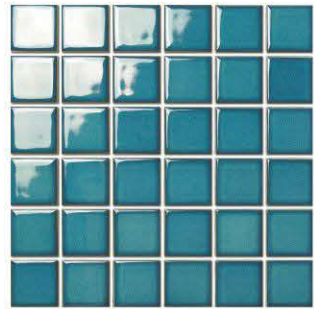

BHP06020 (glossy)



BHP06096 (glossy)

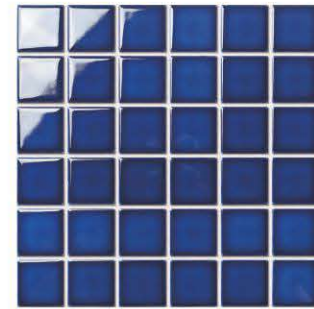

HP0006 (glossy)

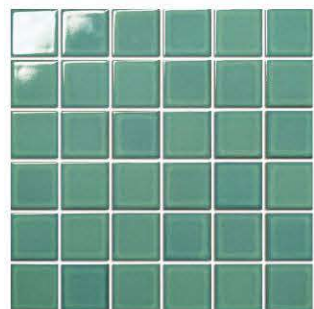

BHP06152 (glossy)



BHP06154 (glossy)

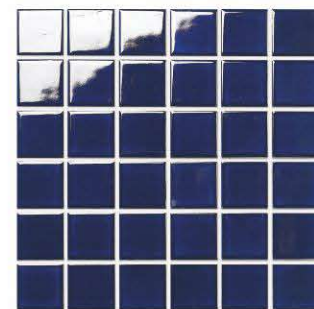

HP08A56 (glossy)

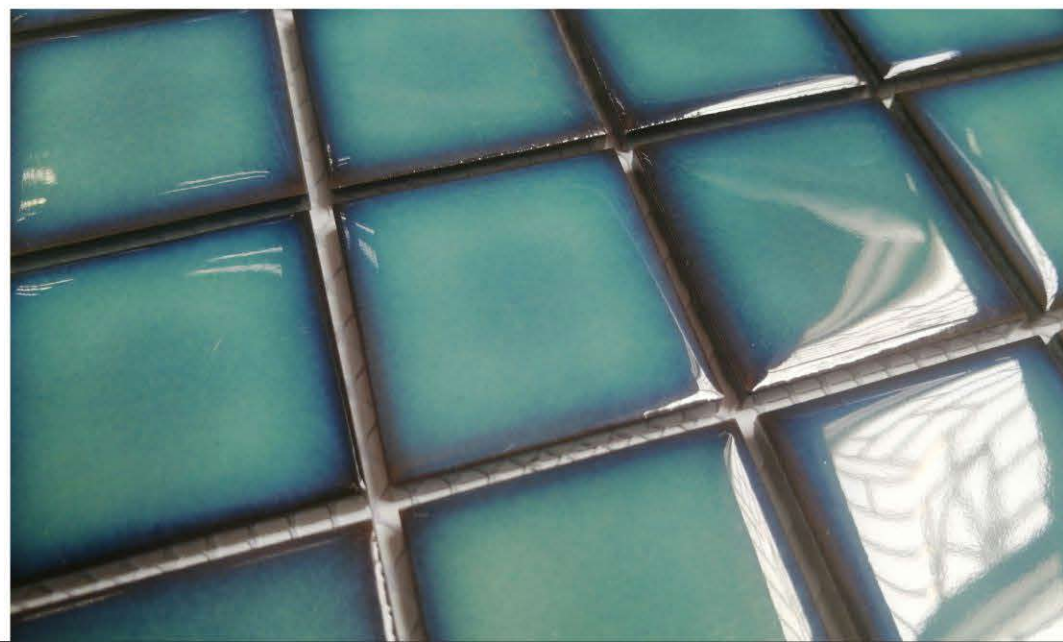



碧海蓝天系列 BH SERIES

产品信息 / Product information

单粒规格 / Chip Size: 23X23mm
 联长尺寸 / Sheet size: 300X300mm (含缝 / included joints)

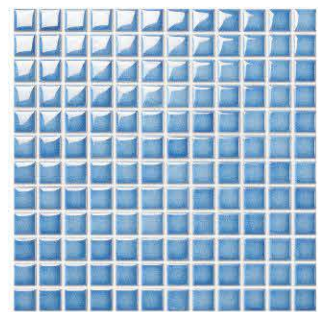

BHX18185 (glossy)

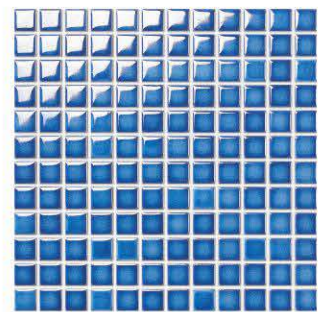

BHX18184 (glossy)

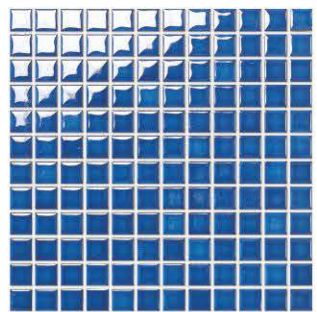

BHX8020 (glossy)

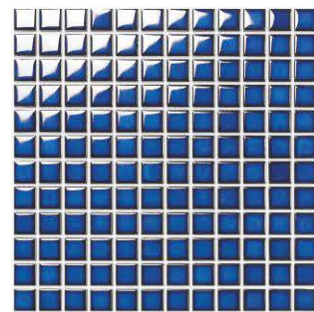

HX08A56 (glossy)

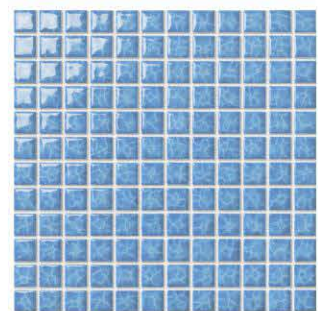

BHX21640 (glossy)

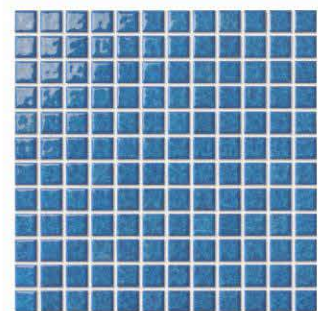

BHX21638 (glossy)

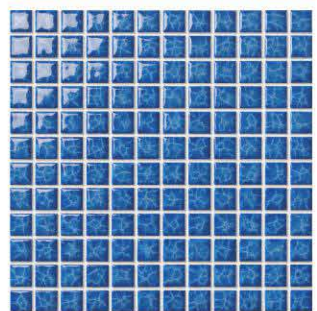

BHX21639 (glossy)

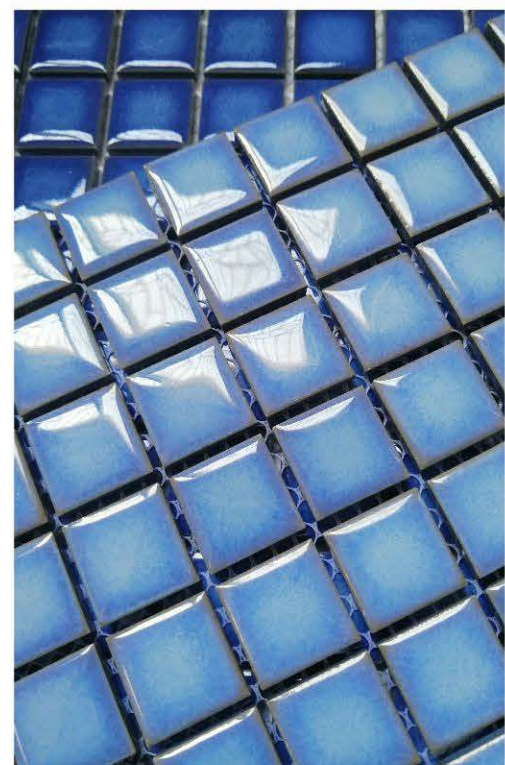

BHX31640 (glossy)

BHX21640 34%
 BHX21638 33%
 BHX21639 33%

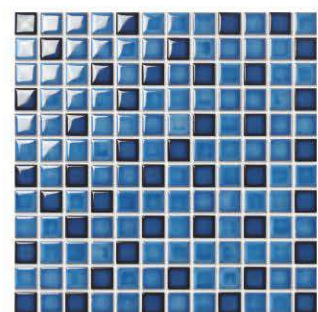

BHX2801 (glossy)

HX08A56 40%
 BHX18184 60%

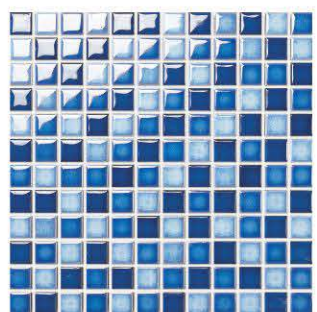

BHX001 (glossy)

BHX8020 33%
 BHX18184 33%
 BHX18185 34%

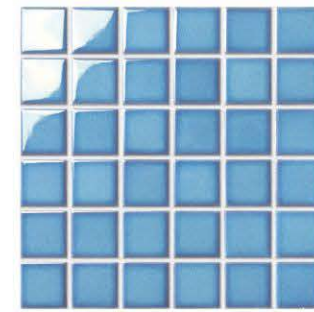

BHP18185 (glossy)

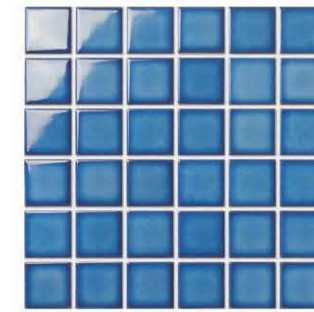

BHP18184 (glossy)

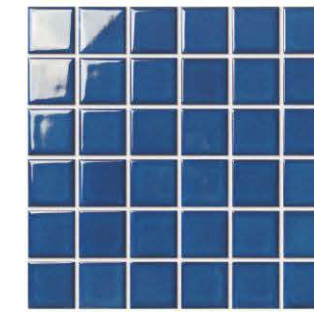

BHP8020 (glossy)

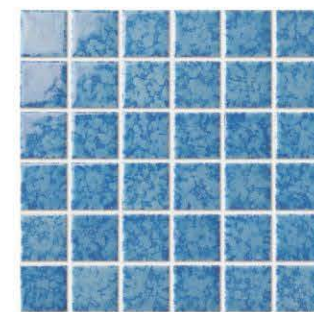

BHP23937 (glossy)

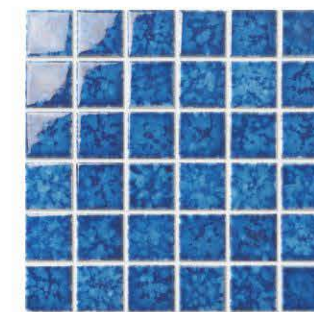

BHP23938 (glossy)

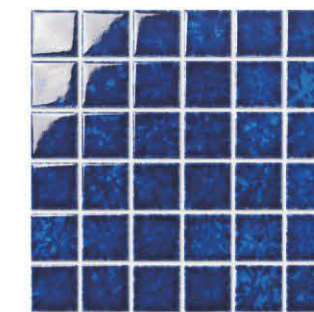

BHP23939 (glossy)

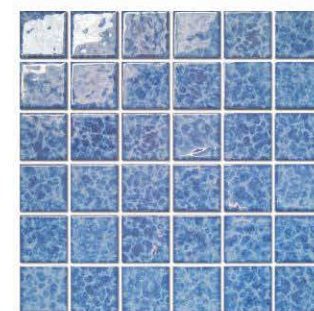

BHP08286 (glossy)

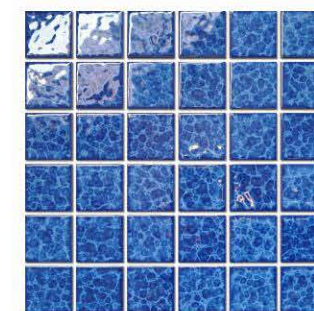

BHP08288 (glossy)

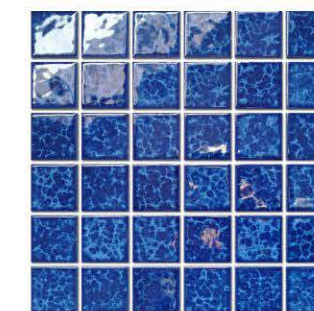

BHP08290 (glossy)

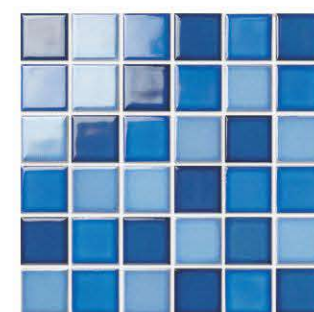

BHP001 (glossy)

BHP8020 33%
 BHP18184 33%
 BHP18185 34%

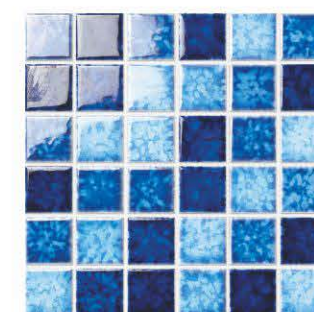

BHP029M (glossy)

BHP23939 33%
 BHP23938 33%
 BHP23937 34%



冰山雪莲系列 HBP SERIES

产品信息 / Product information

单粒规格 / Chip Size: 48X48mm

联长尺寸 / Sheet size: 306X306mm (含缝 / included joints)

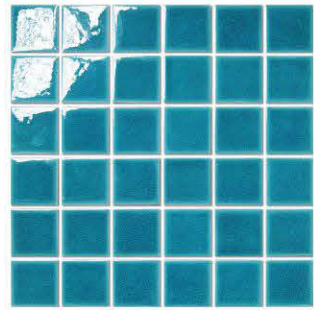
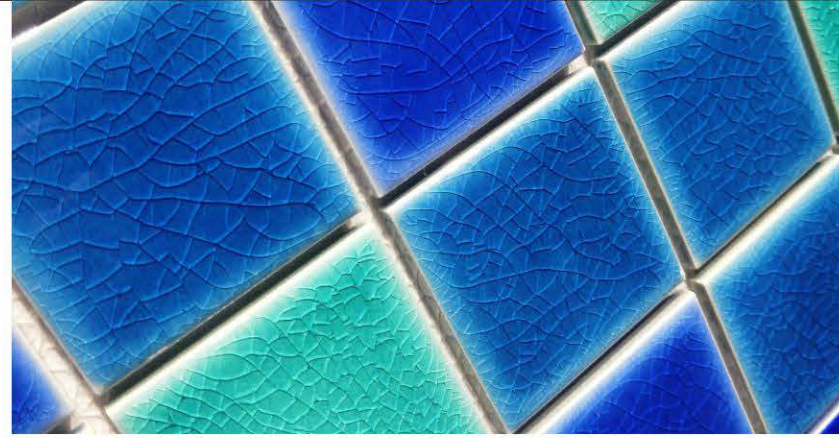

NEW HPBB8042 (glossy)

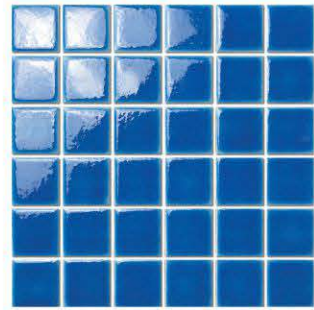

HPBB8034 (glossy)

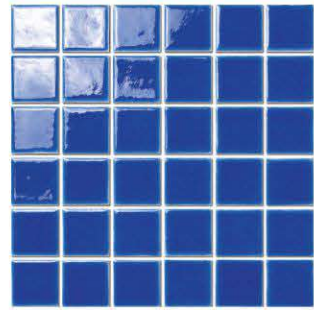

HPBB8036 (glossy)

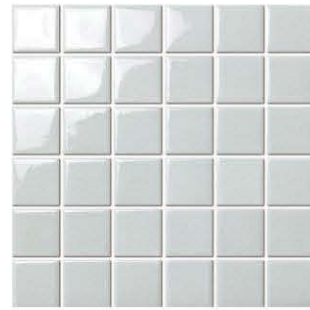

HPBP0101 (glossy)

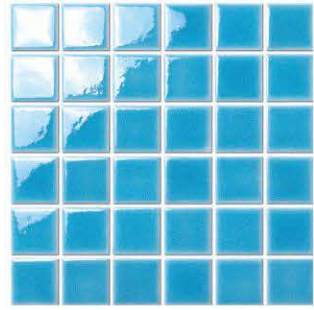

HPBB8030 (glossy)

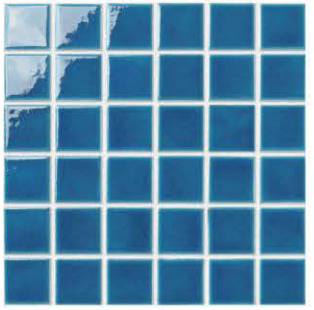

HPBB8010 (glossy)

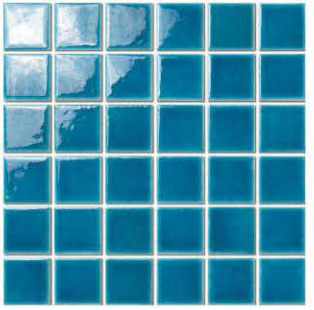

HPBB8028 (glossy)

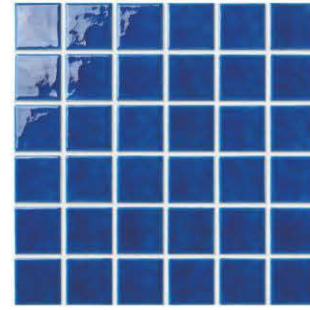

HPBB8016 (glossy)

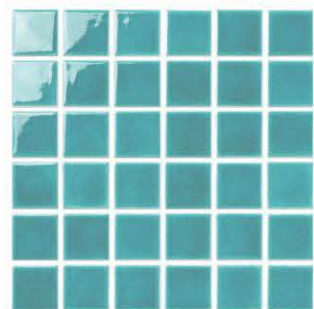

HPBA6008 (glossy)



HPBA6014 (glossy)

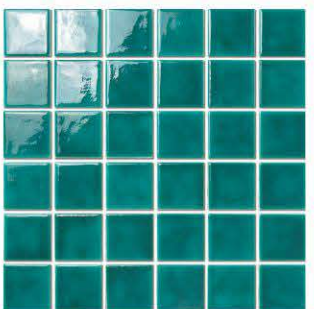

HPBA6010 (glossy)

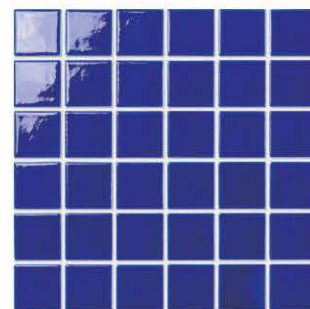

HPBB8014 (glossy)



HPBMIX001 (glossy)

HPBB8014 11%
HPBB8016 22%
HPBB8010 42%
HPBA6008 25%

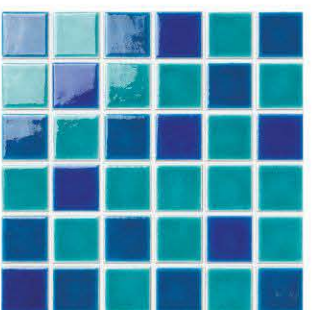

HPB010M (glossy)

HPBB8016 20%
HPBB8010 30%
HPBA6008 50%

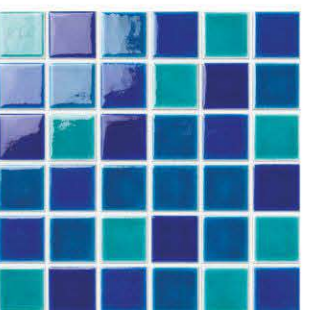

HPB088M (glossy)

HPBB8014 20%
HPBB8016 25%
HPBB8010 30%
HPBA6008 25%

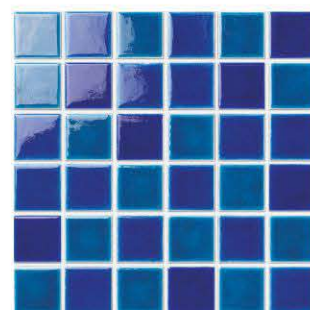

HPB013M (glossy)

HPBB8014 20%
HPBB8016 40%
HPBB8010 40%

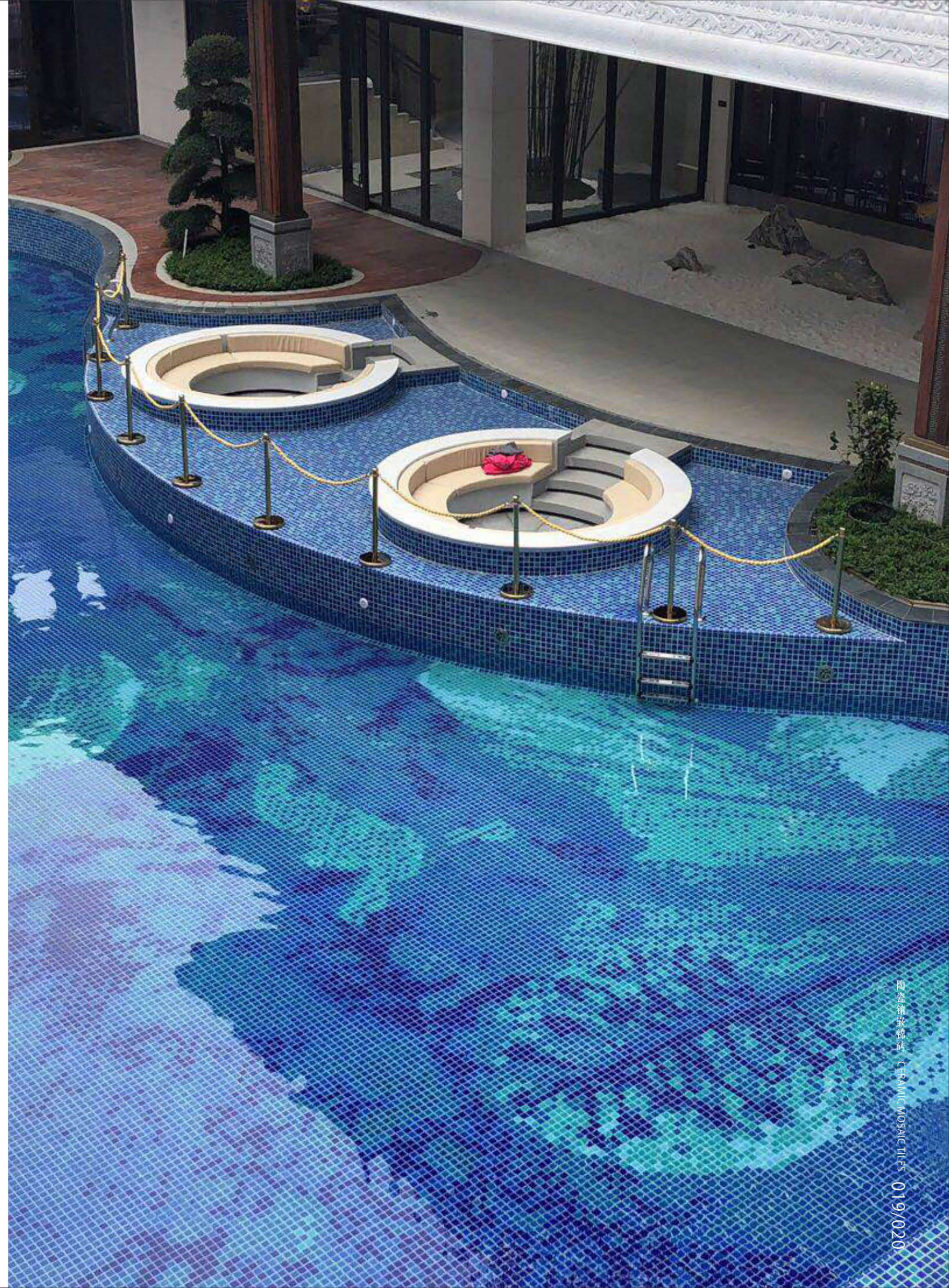



冰山雪莲系列 HBP SERIES

产品信息 / Product information

单粒规格 / Chip Size: 23X23mm
联长尺寸 / Sheet size: 300X300mm (含缝 / included joints)

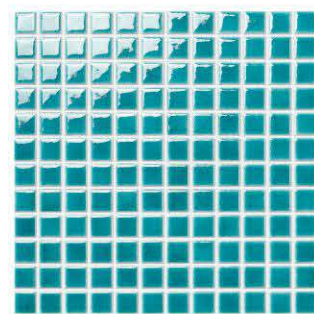

HXBA6008 (glossy)

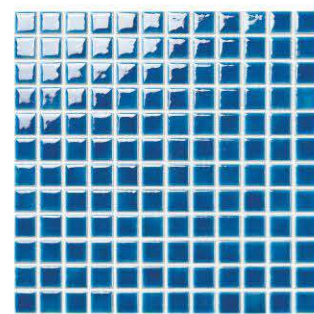

HXBB8010 (glossy)

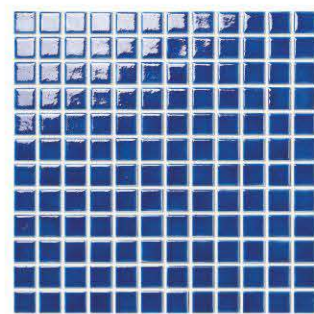

HXBB8016 (glossy)

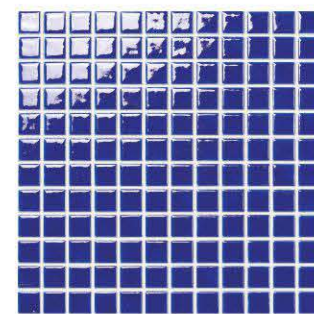

HXBB8014 (glossy)

产品信息 / Product information

单粒规格 / Chip Size: 73X73mm
联长尺寸 / Sheet size: 306X306mm (含缝 / included joints)

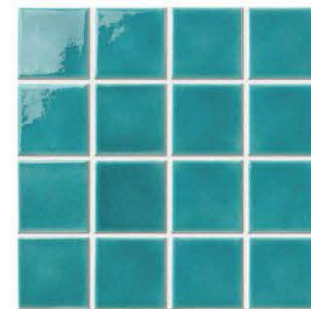

HFBA6008 (glossy)

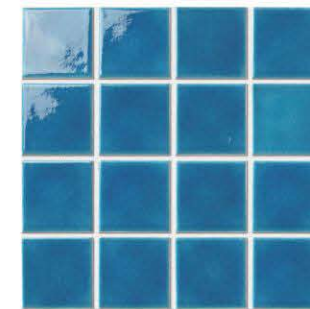

HFBB8010 (glossy)

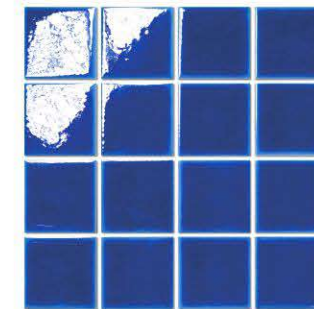

HFBB8016 (glossy)

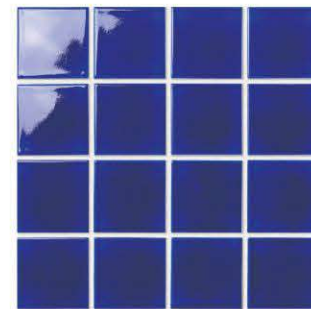

HFBB8014 (glossy)

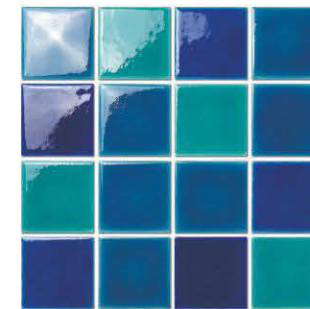

HFBMIX001 (glossy)

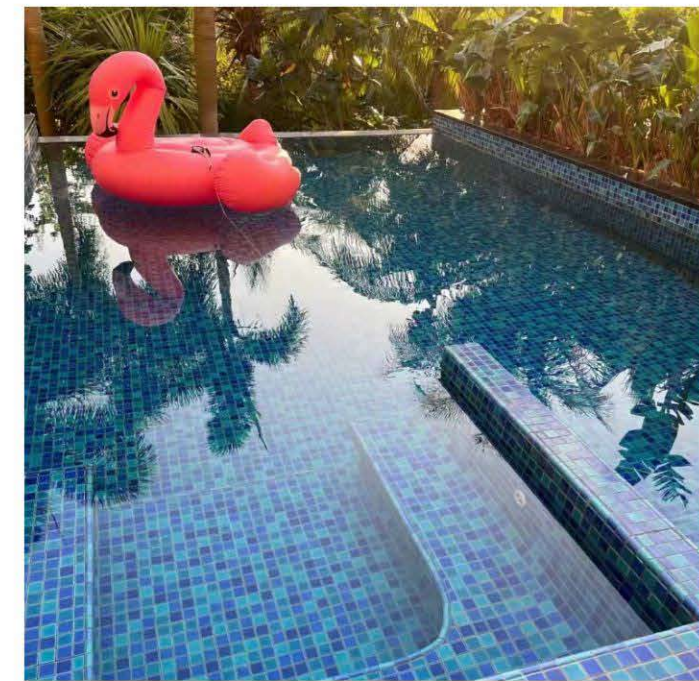

产品信息 / Product information

单粒规格 / Chip Size: 95X95mm
联长尺寸 / Sheet size: 295.5X295.5mm (含缝 / included joints)

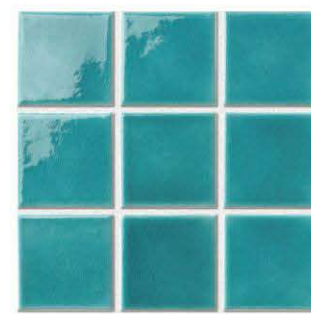

HNBA6008 (glossy)

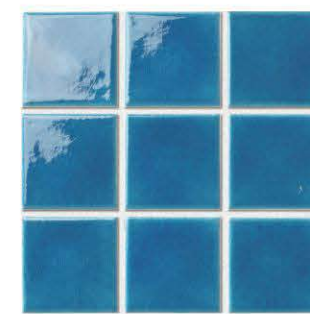

HNBB8010 (glossy)

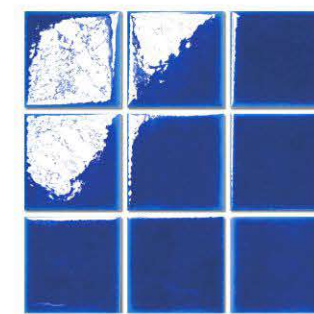

HNBB8016 (glossy)

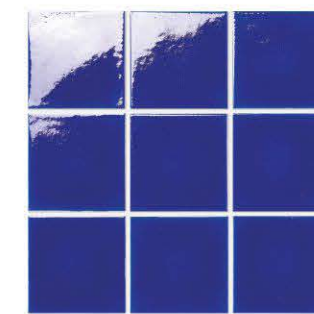

HNBB8014 (glossy)

青山绿水系列 GREEN SERIES

产品信息 / Product information

单粒规格 / Chip Size: 23X23mm
联长尺寸 / Sheet size: 300X300mm (含缝 / included joints)

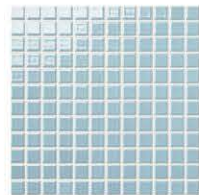

HX08A30 (glossy)

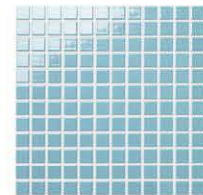

HX23012 (glossy)

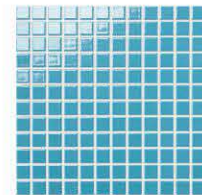

HX0808 (glossy)

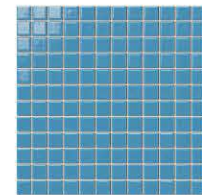

HX08052 (glossy)

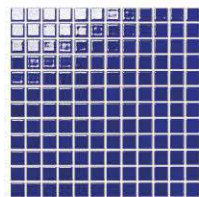

HX08A16 (glossy)

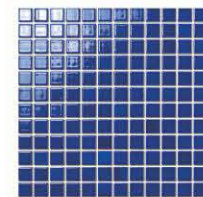

BHX21541 (glossy)

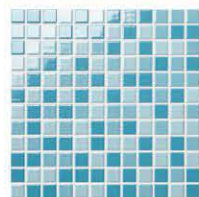

HX144 (glossy)

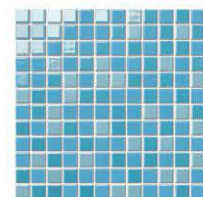

HX142 (glossy)



产品信息 / Product information

单粒规格 / Chip Size: 48X48mm
联长尺寸 / Sheet size: 306X306mm (含缝 / included joints)

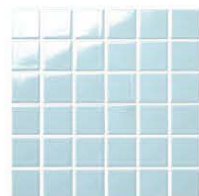

HP08A30 (glossy)

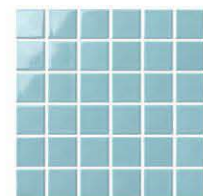

HP13012 (glossy)

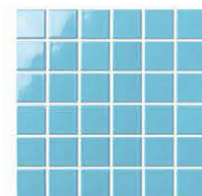

HP13075 (glossy)

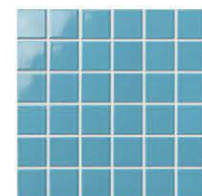

HP08052 (glossy)

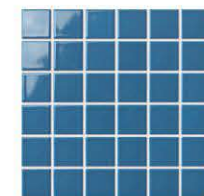

HP08A48 (glossy)

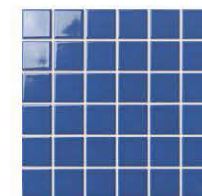

HP08A50 (glossy)



BHP21541 (glossy)

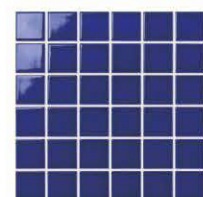

HP08A52 (glossy)

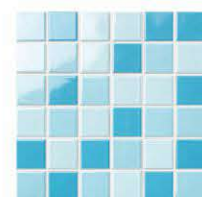

HP013M (glossy)

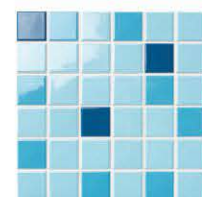

HP023M (glossy)



HP015M (glossy)

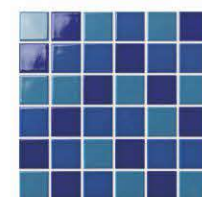

HP308A48 (glossy)

拼花装饰线系列 WATER LINES

73mm拼花装饰线 / 73mm WATER LINES

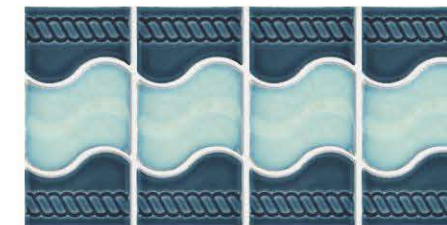

YX17478 (glossy)

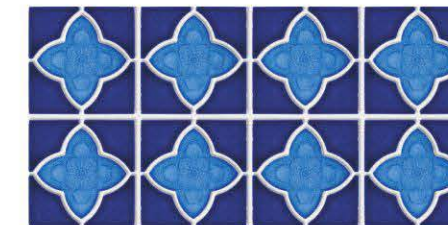

YXF80006 (glossy)

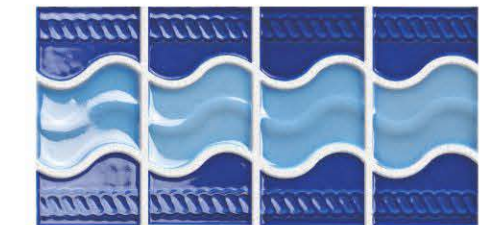

YX17479 (glossy)

48mm拼花装饰线 / 48mm WATER LINES



YX17311 (glossy)



YX17313 (glossy)



YX17318 (glossy)

23mm拼花装饰线 / 23mm WATER LINES

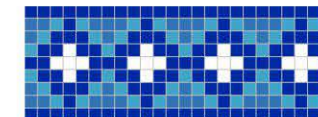

YXX013 (glossy)



YXX014 (glossy)

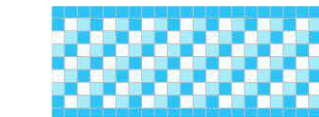

YXX015 (glossy)

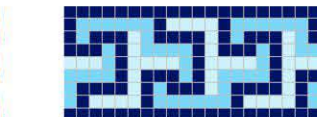

YXX016 (glossy)

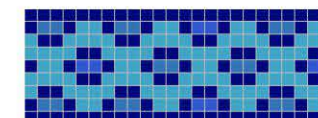

YXX017 (glossy)

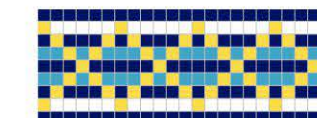

YXX018 (glossy)

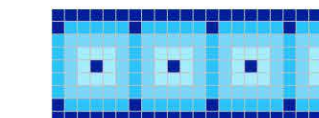

YXX019 (glossy)

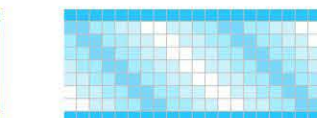

YXX020 (glossy)



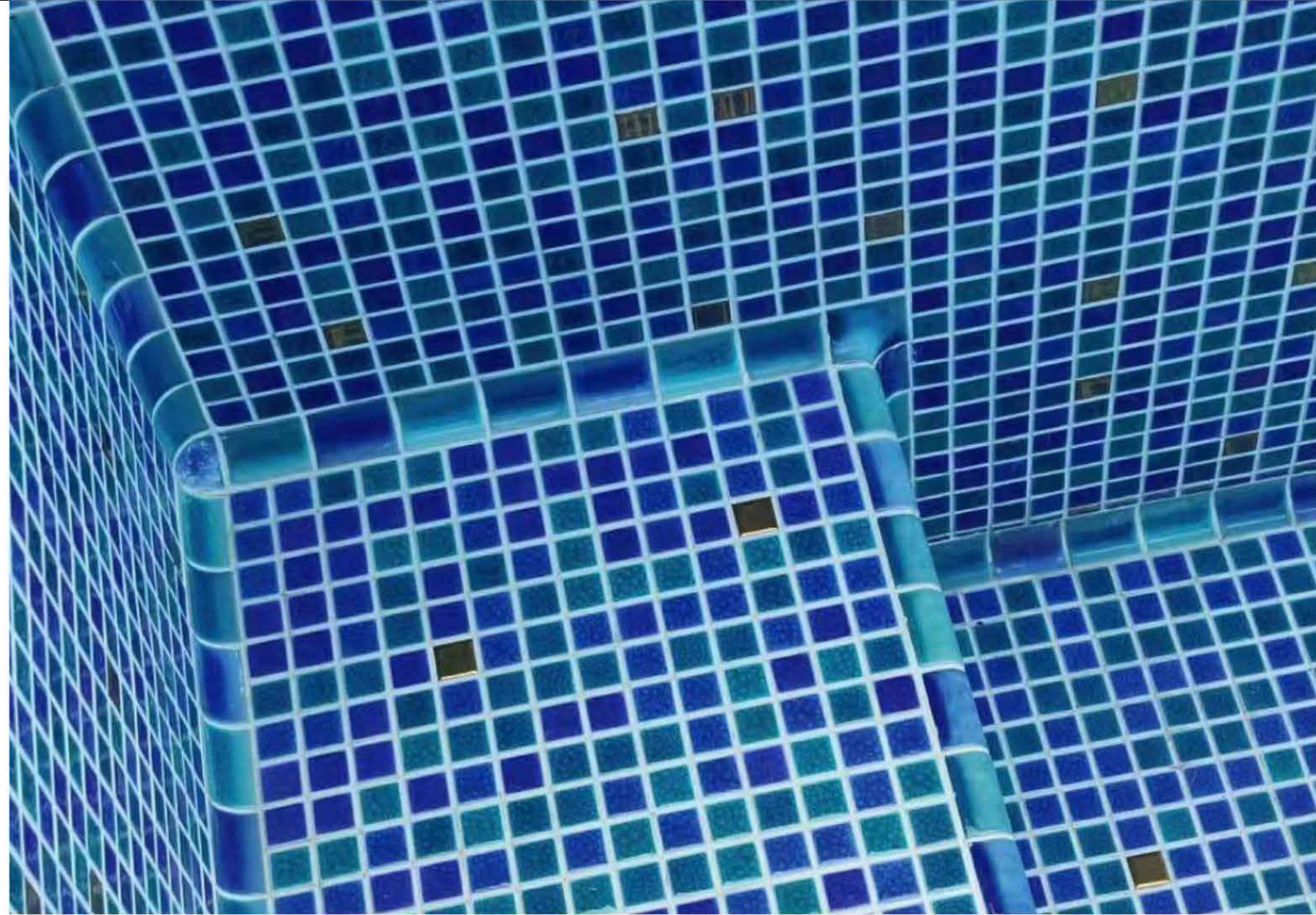

泳池配件 TRIMS & CORNERS

48x48mm配件

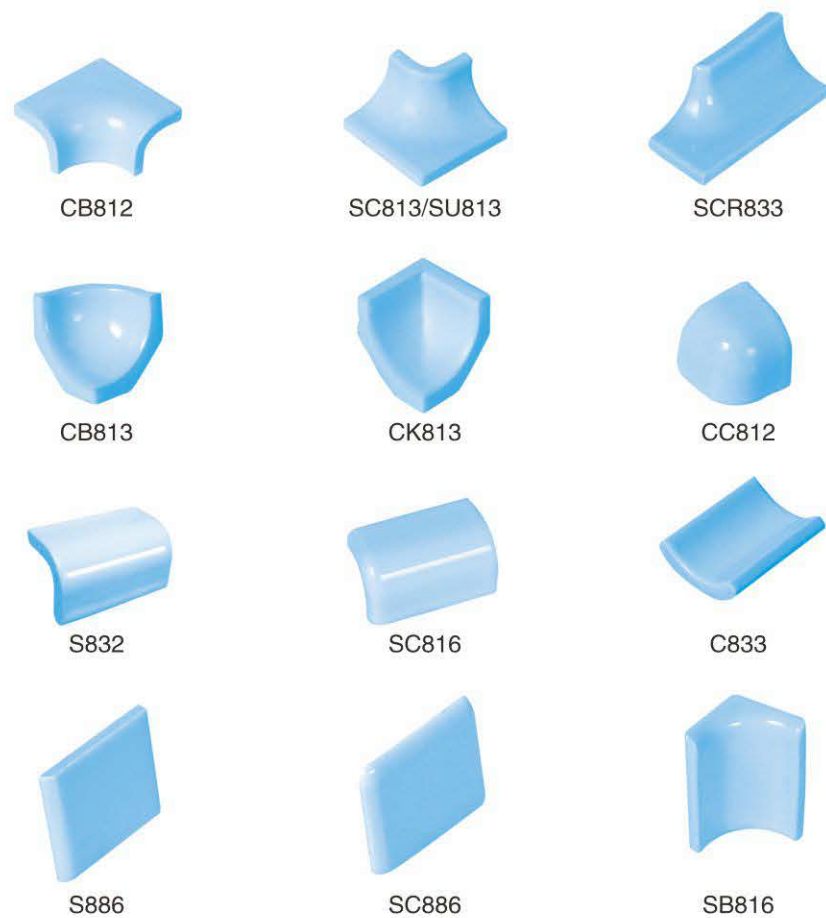

95x95mm配件



73x73mm配件

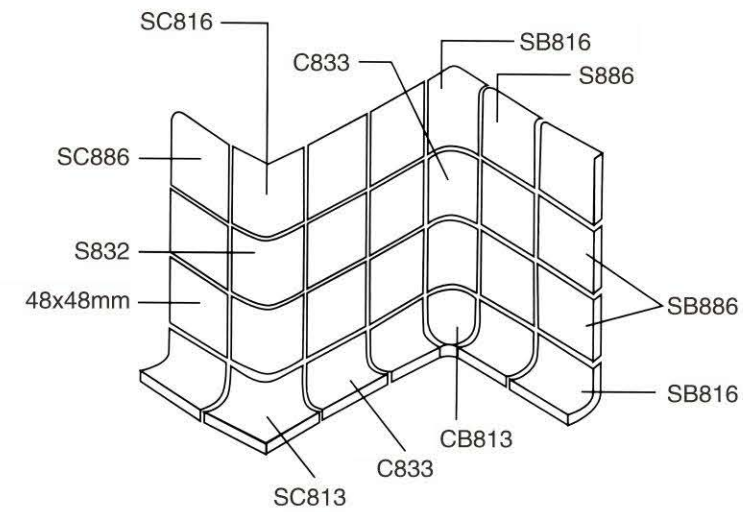
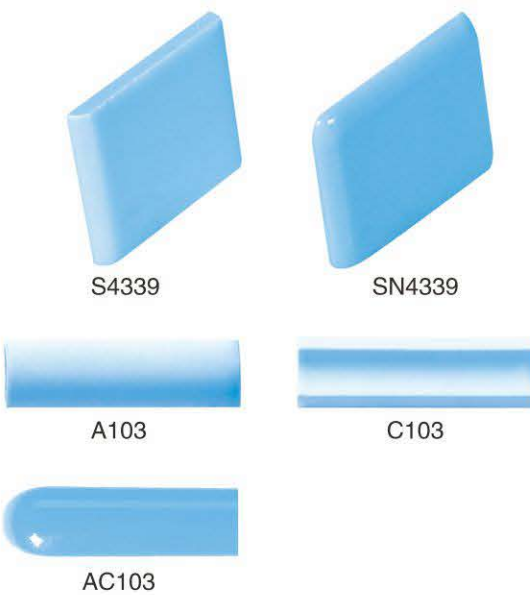

彩花泳池马赛克人性化设计理念：生产多样化配件，体现彩花的人文关怀精神。

- ▶ 有助于梯级和泳池处角的完美修饰；
- ▶ 圆形修饰边角可避免碰伤身体；
- ▶ 方便清洁，无卫生死角。

The humanization design concept of CAIHUA pool mosaic: Produce all kinds of trims and corners to matching supply with pool mosaic, embody the spirit of humanistic care.

- ▶ Make a perfect decoration for the steps and edges of the pool;
- ▶ Rounded corners can avoid body bruised;
- ▶ Convenient and clean, no health dead corner.

48x48mm配件实景图

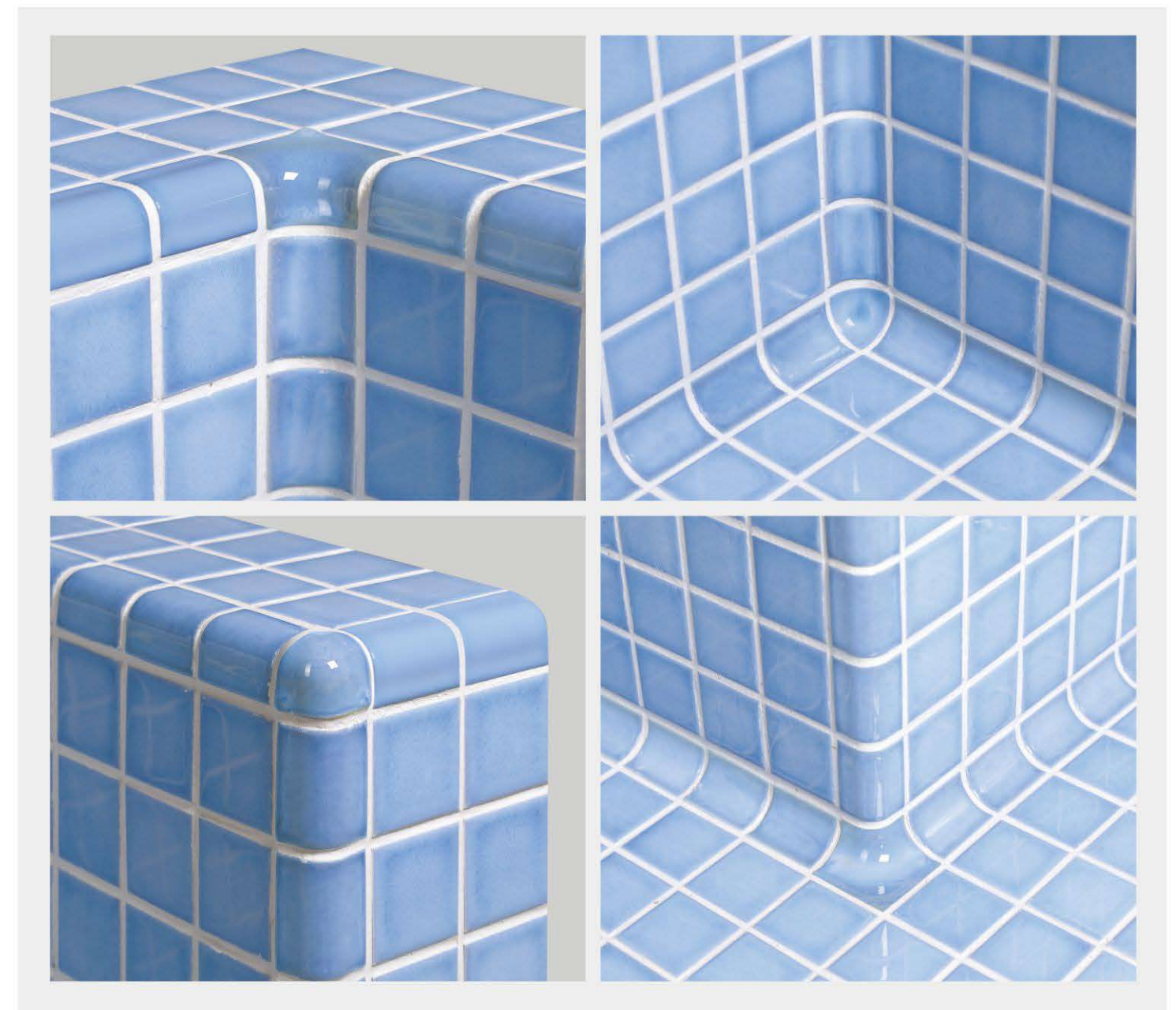

设计案例 DESIGN CASES

我公司设计部将会根据泳池工程平面图，箱客户提供多种的设计方案，务求满足客户的不同需求。以下是我们的几款设计方案，供您参考。

Our designers will provide you some designs according to the plan metric map of your swimming pool, in order to meet the design needs of every customer. Please see the following designs for your Reference.

1. 高级酒店、度假村、住宅小区的泳池设计方案: Designing scheme of public swimming pool for Hotel & Resorts & Residence.

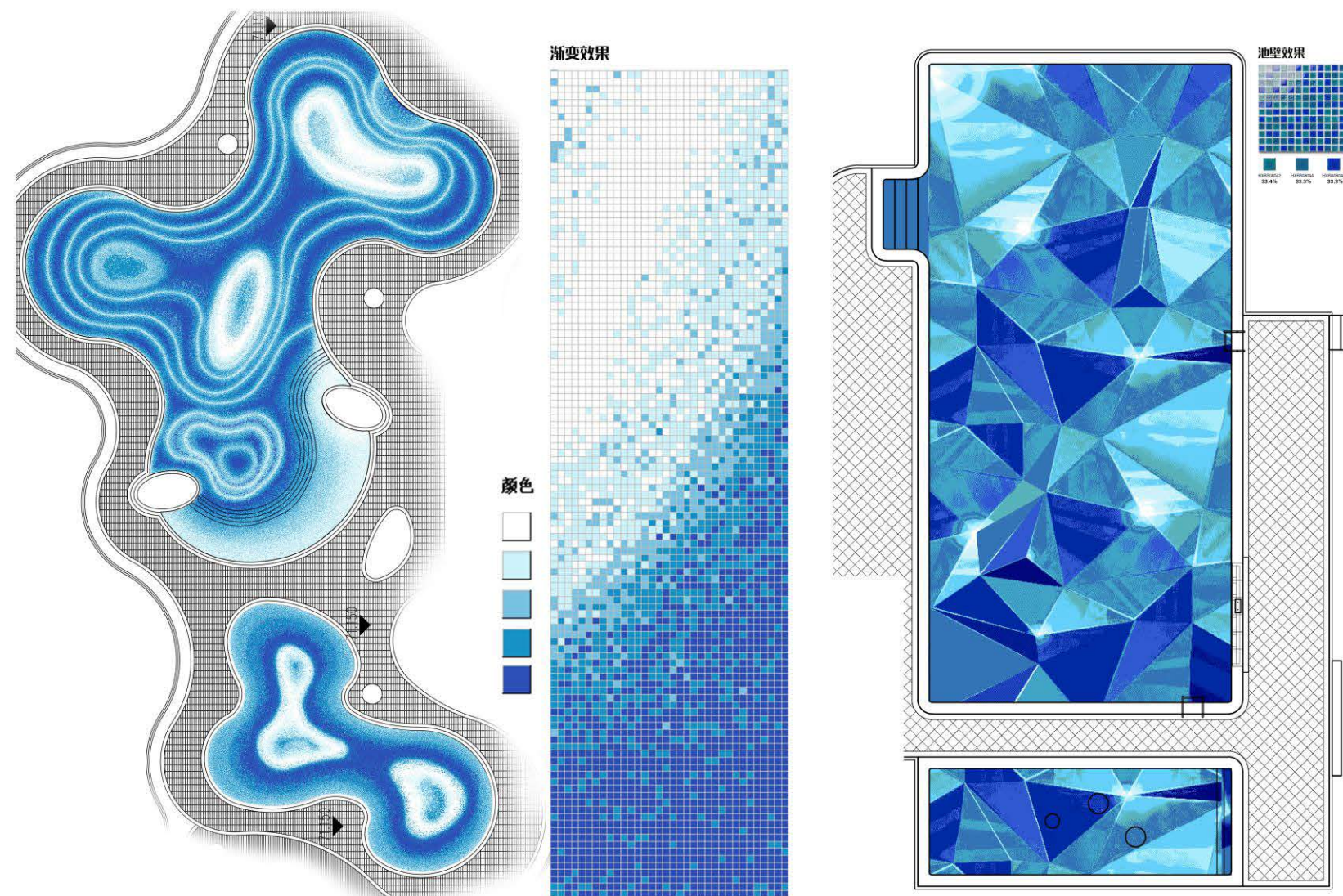
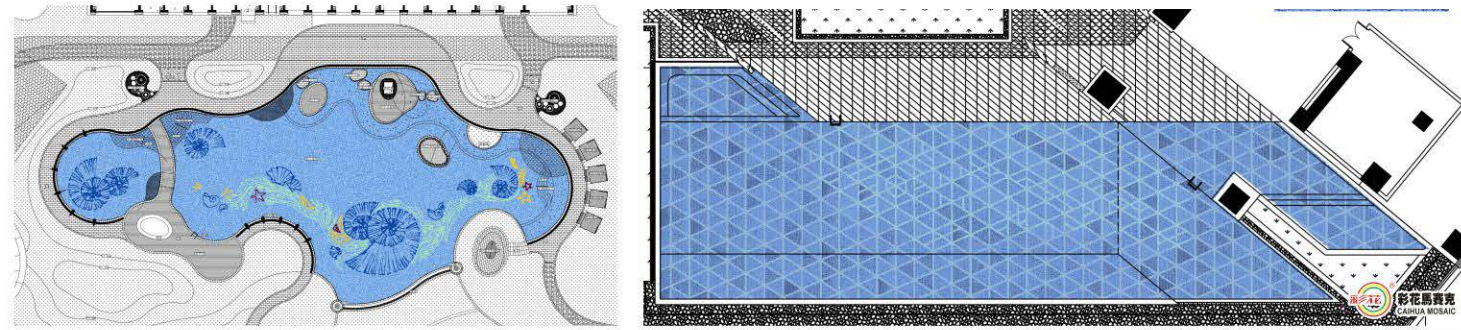

2. 别墅泳池的设计方案: Designing scheme of private swimming pool.

* 这是业主提供的CAD图
Here is the CAD file given by the owner.

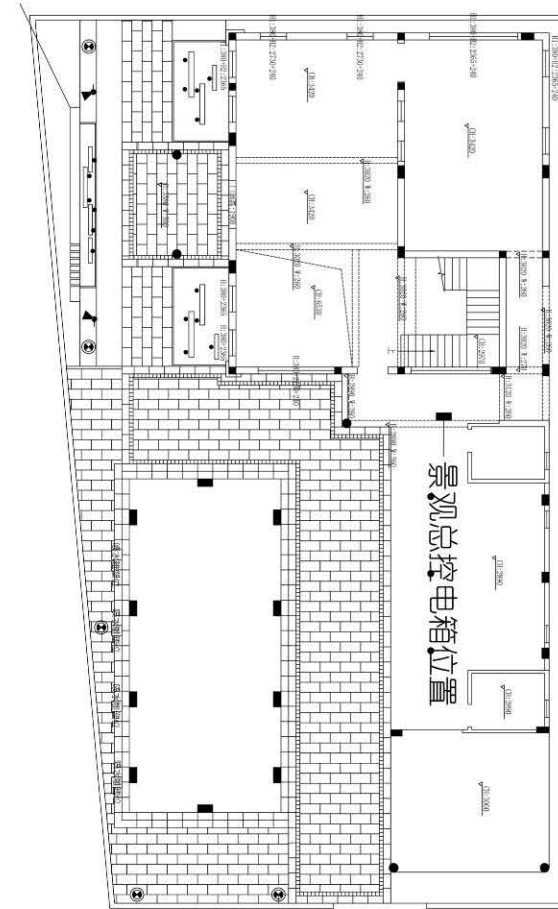

* 这是我公司提供的设计方案一。
Here is the our designing scheme 1.

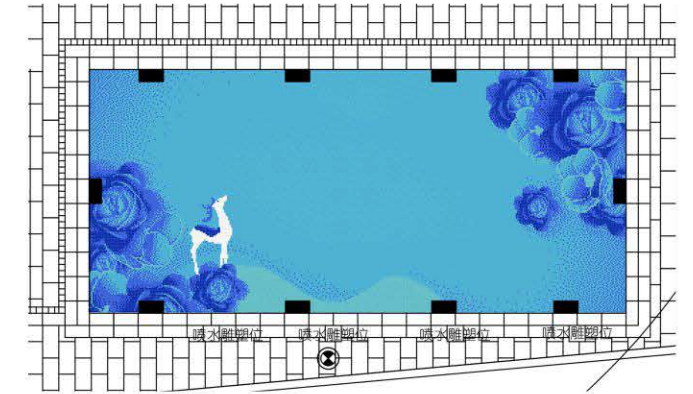

* 这是我公司提供的设计方案二。
Here is our designing scheme 2.

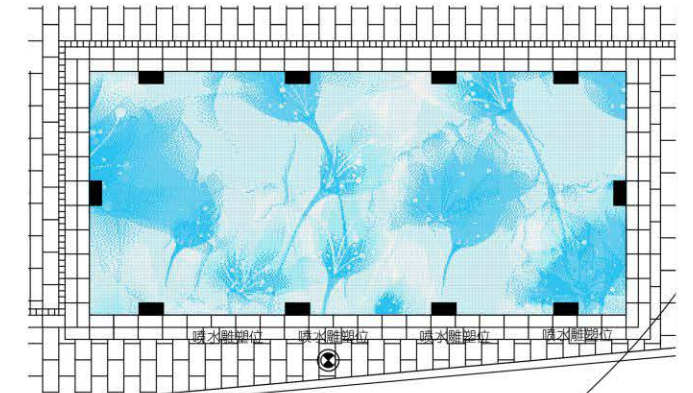

3. 幼儿园泳池的设计方案。 Designing scheme of swimming pool of kindergarten.

* 这是幼儿园提供的CAD图。
Here is the CAD file of a Kindergarten.

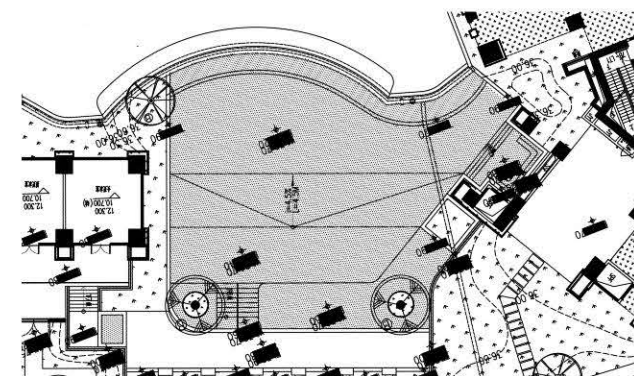

* 这是我们的设计方案。
Here is our designing scheme.

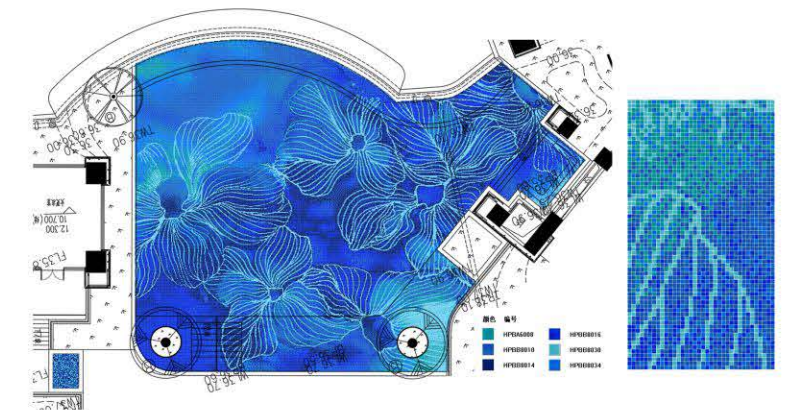

工程案例 PROJECT CASES

龙光地产汕头御海天辰泳池项目

我公司设计部配合龙光地产不断优化完善泳池设计方案，与龙光地产建立了长期的合作关系。

设计方案初稿

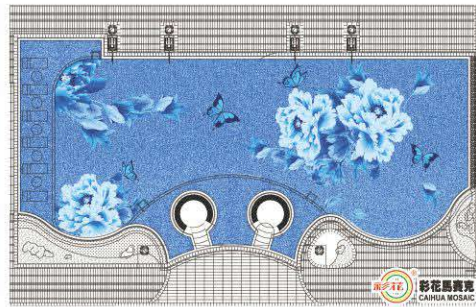

设计方案终稿



现场效果图



惠州星河荣域花园泳池项目

我公司设计部配合惠州星河荣域花园完善泳池设计方案。

星河荣域花园 泳池设计方案

成人泳池面积约625平方米 儿童池约14.6平方米 (按1米深计算)

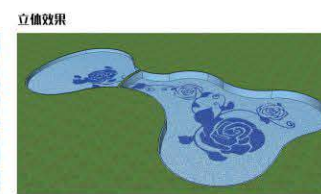
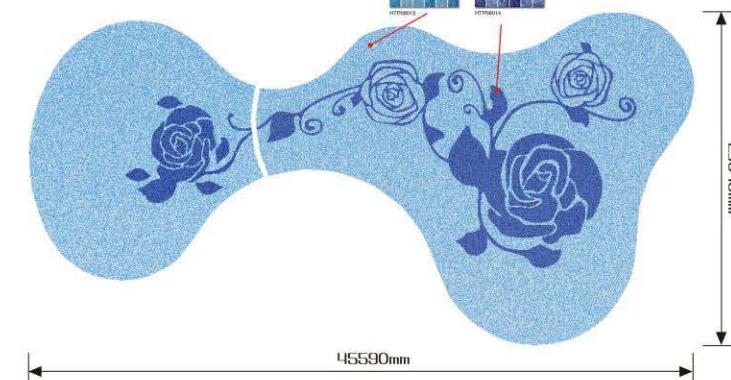

工程案例 PROJECT CASES

杭州亚运村泳池项目

我公司设计部配合杭州亚运村完善泳池设计方案。

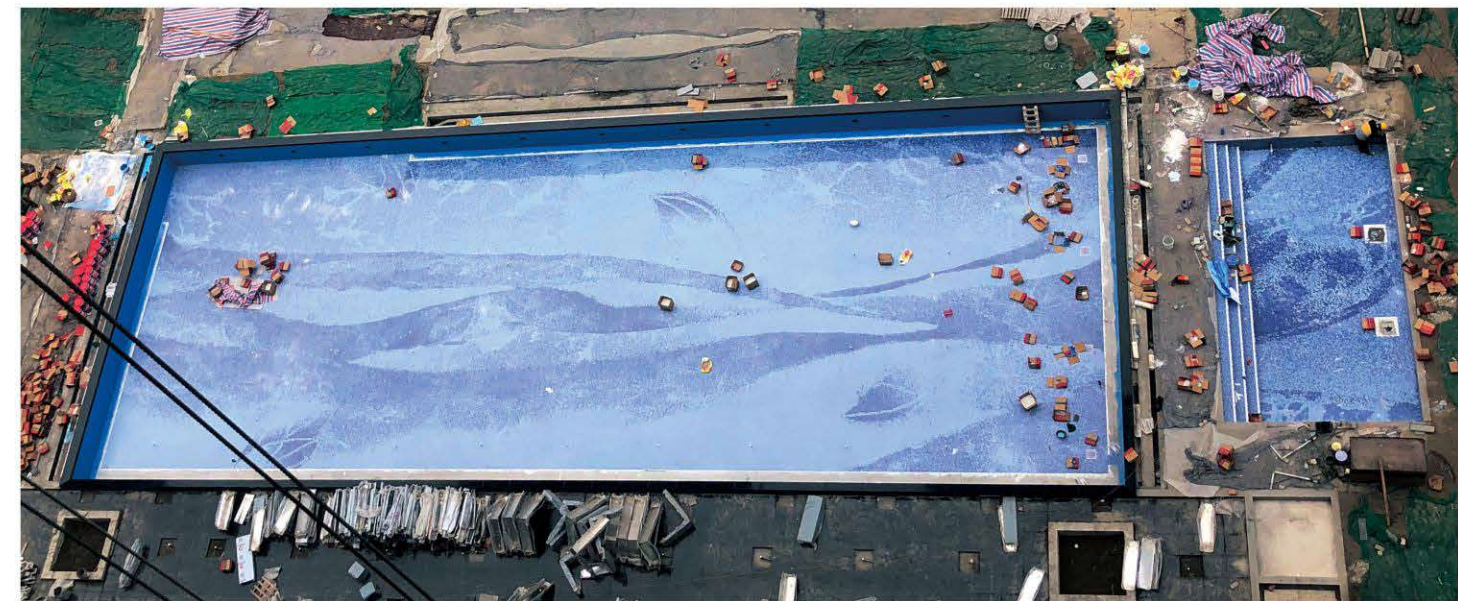
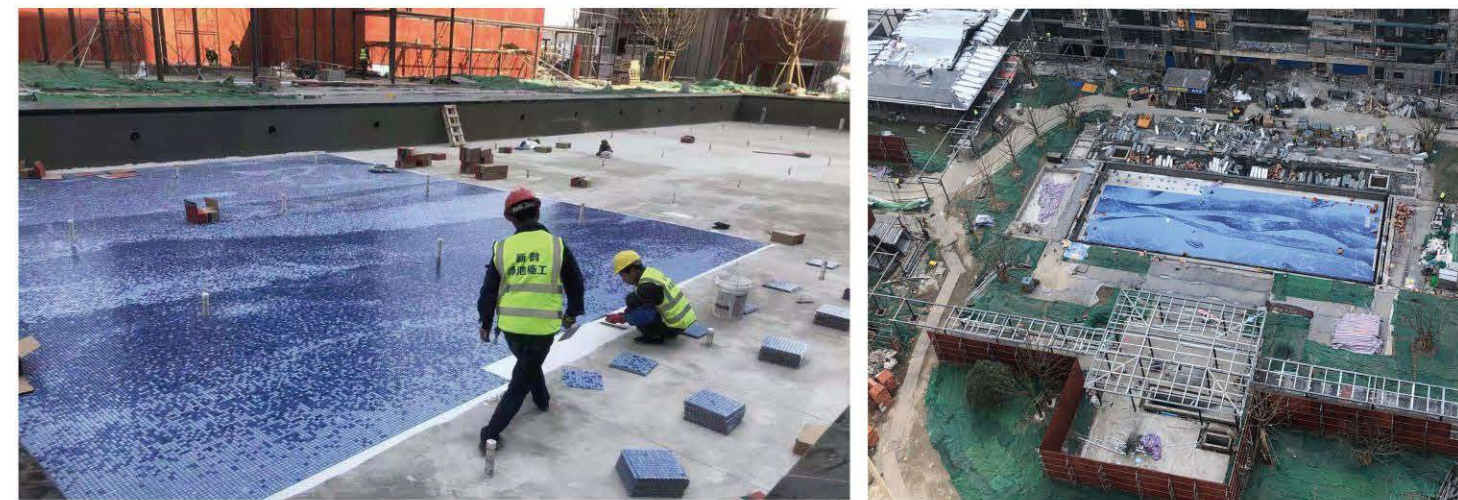
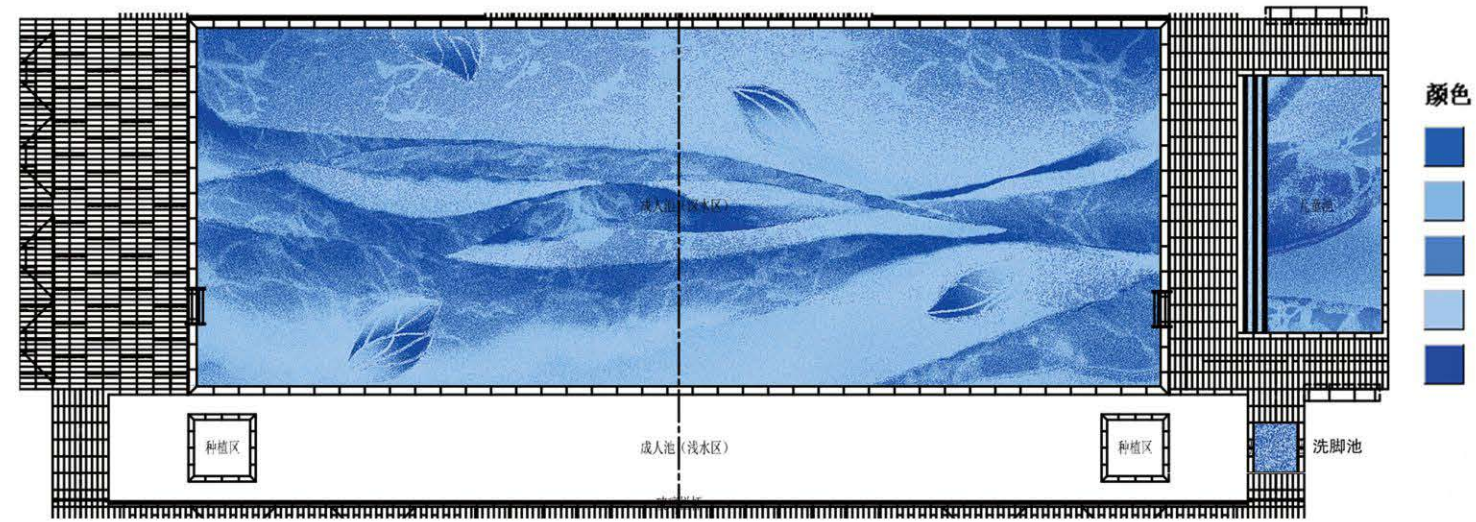

▼ 马来西亚私人别墅

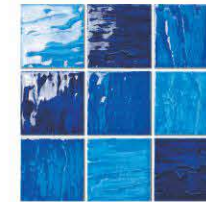
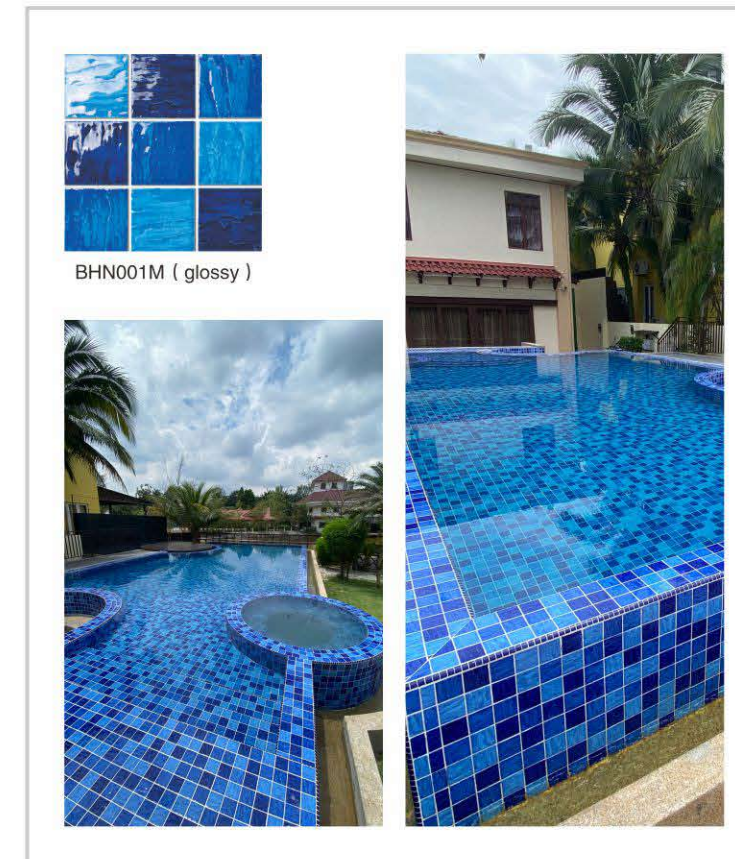

BHN001M (glossy)



▼ 广东省惠州市金裕星河梧桐湾花园

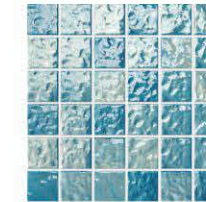

HTP08012 (glossy)

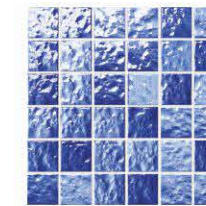

HTP08014 (glossy)

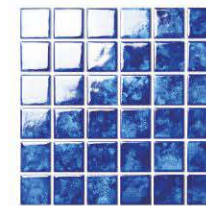
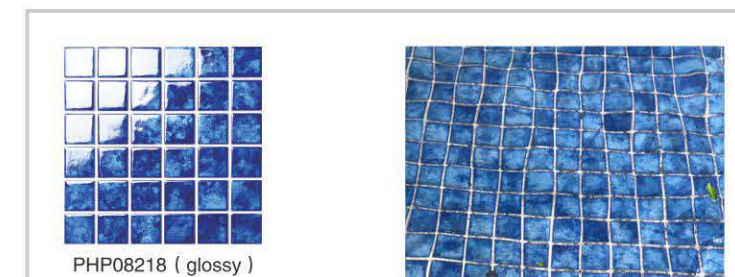

PHP08218 (glossy)

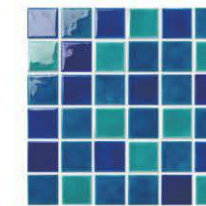

HPBMIX001 (glossy)

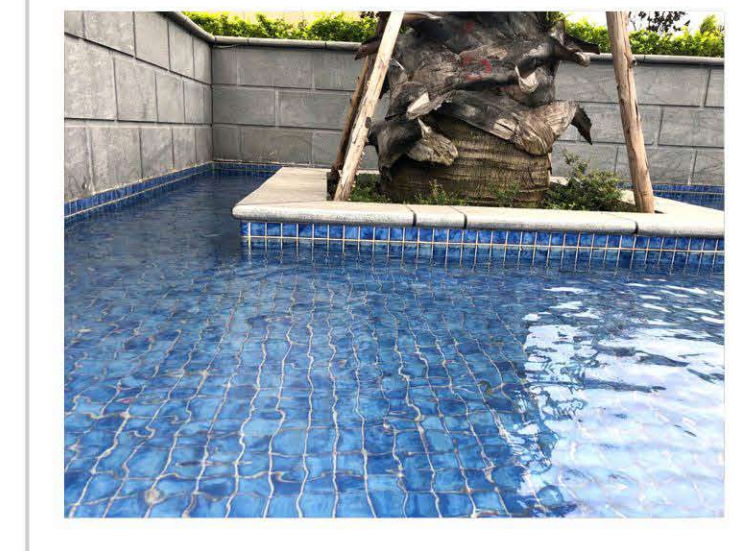

▲ 广西北海酒店



▲ 广州增城碧桂园金叶子温泉度假酒店

工程案例 PROJECT CASES

▼ 海南省海口市威斯汀酒店



▼ 湖南永州万象城

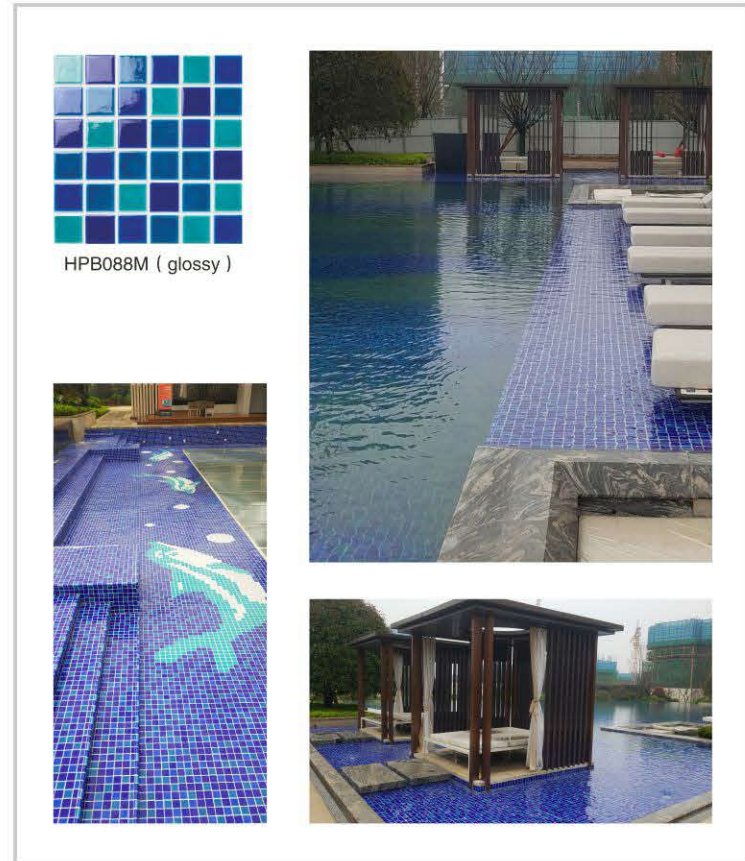

▲ 福建省三明市吉祥福邸花园

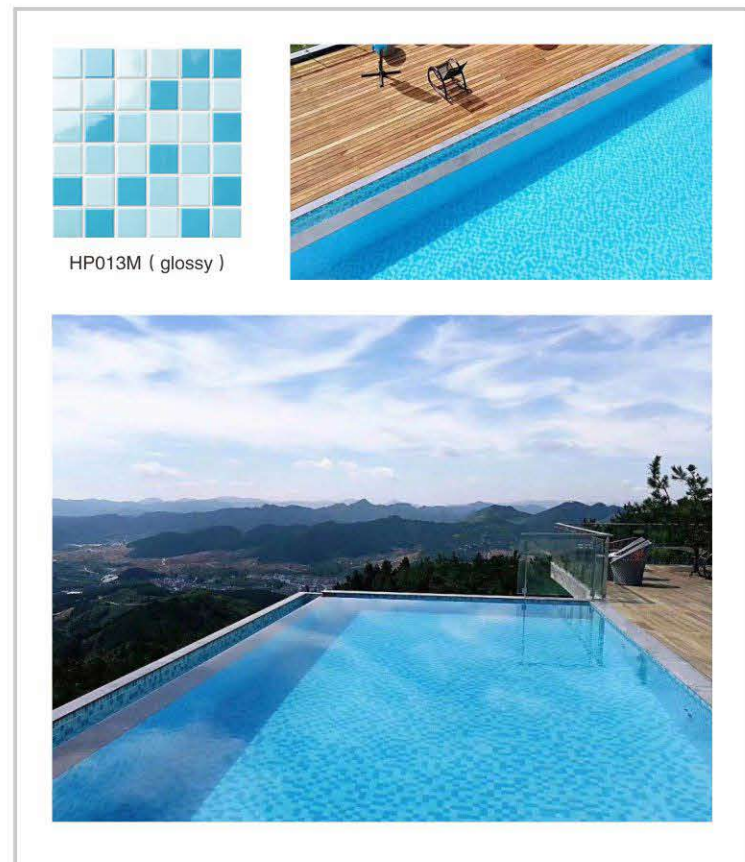

▲ 浙江金华磐安玉岑山居

▼ 广东省惠州市惠东大亚湾碧桂园翡翠山 (拼图)

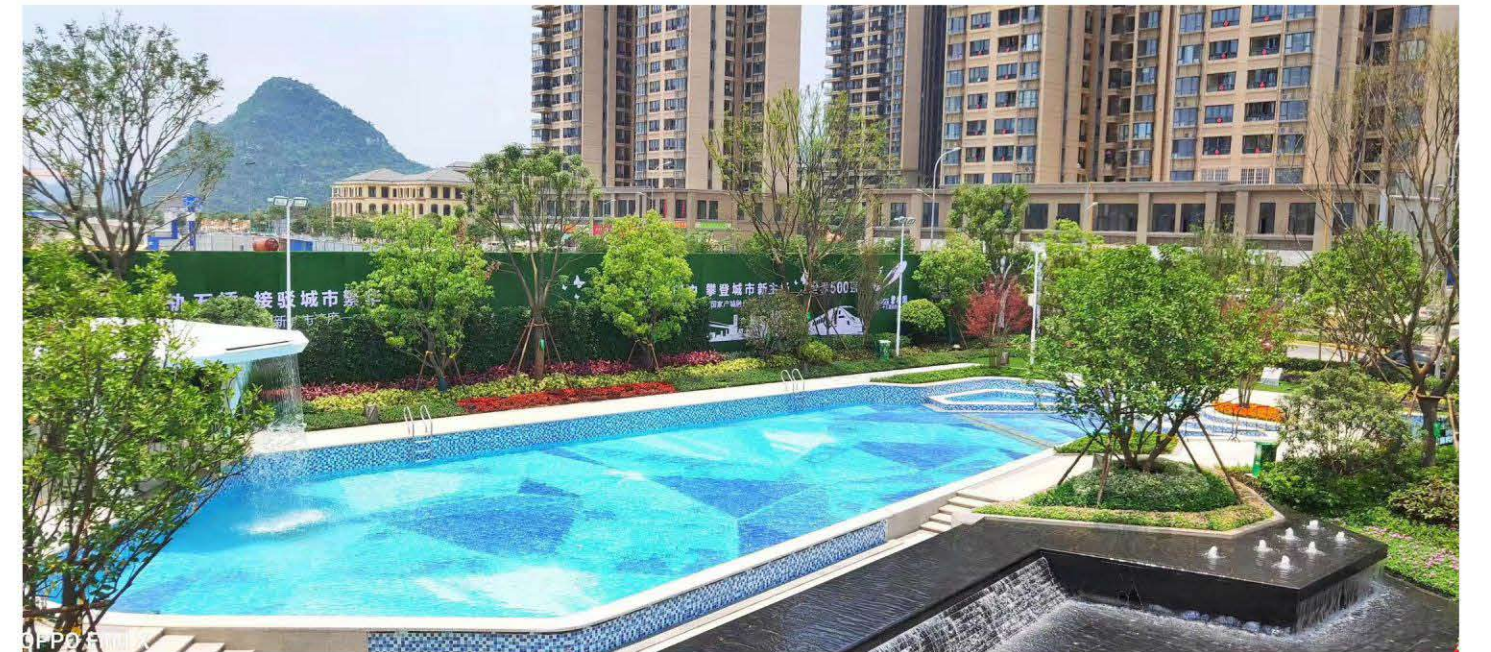

▲ 广东省佛山市里水镇碧桂园云樾金沙小区 (拼图)



▲ 东方市傲月丽呈酒店 (拼图)

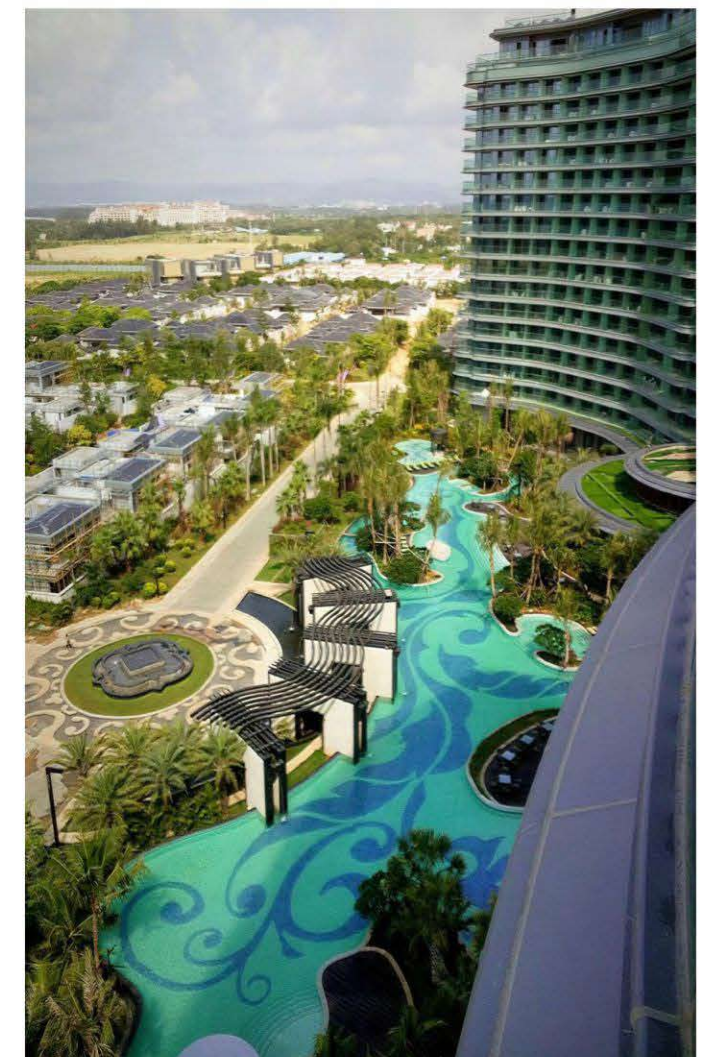

▲ 海南省三亚市葛州坝酒店 (拼图)

产品资讯 PRODUCTS INFORMATION

1. 技术参数 Technical Data,

Item项目	CAIHUA Mosaic Standard彩花马赛克标准
Water Absorption吸水率	≤0.5%
Breaking Strength抗折度	60Mpa
Dimension tolerance尺码公差	± 1.2%
Thermal shock resistance抗热震	Resistance
Chemical resistance耐化学物品	Resistance

2. 特别推荐:点胶铺贴产品 (如图)

彩花马赛克有纸贴产品、网贴产品及点胶铺贴产品。我公司特别推荐的是点胶铺贴产品，此铺贴方法已在中国获得发明专利，用此方法铺贴的产品，其优点是产品不会脱落、定位好，施工方便，不受气候及存放地方的限制，除此以外，它最大的优点是胶点遮盖砖底的面积很少，砖底面积超过75%能够通过水泥或粘胶与墙面或地面牢固粘合，确保马赛克不脱落。这优点对需要在泳池或园林水景铺贴马赛克是最适合。

Special comment: Dot mounted products (as picture)

CAIHUA Mosaic will be packed in paper face mounted, mesh mounted and dot mounted. We recommend dot mounted products. This kind of dot mounting method had been registered patent in China. The advantage of dot mounted products is that products are always in position, easy installation, and keeping stock easily and never be restricted by the weather. In addition, the most major advantage is that the cover area of the dots is small, over 75% of backside area can be stuck with the ground and wall to avoid mosaic fall off. This advantage is specially suitable for the mosaic which is installed in a pool.

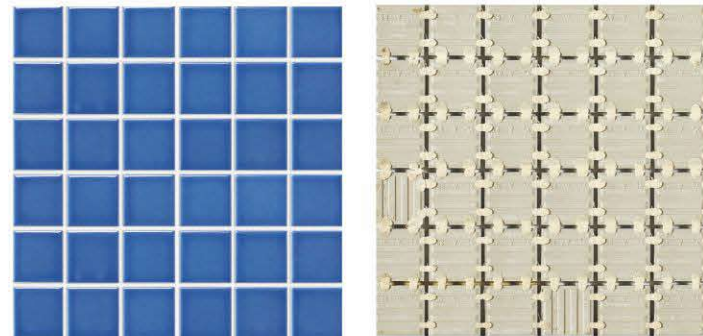

马赛克的施工方法说明 MOSAICS INSTALLATION

顾客的满意度取决于如何选择对熟练运用马赛克艺术的专业人士，这样，彩花马赛克的价值才可以得到充分的体现。

因此，在推动“彩花”品牌的发展中，施工人员成为了重要的、不可缺少的伙伴。我们成功的关键在于我们的专业，在此目录的这一部份中，我们对一些必要的铺贴施工方法作以下快速指南：

1. 检查施工的材料

在施工之前，仔细地检查包装箱里的彩花马赛克，看是否有足够的马赛克来完成工作。在每一个包装箱上面，我们都会显示产品的型号、色号、生产批号、以及其他详细资料。

2. 荡平墙面基础

这个步骤就是要将墙面的基础荡平，荡平后的墙面必须是平滑及同一颜色的。

3. 划线

在墙面上划线来记下每一贴马赛克的准确位置。将3贴马赛克在地面上并排地铺开，使得贴与贴之间灰缝与一贴里的灰缝相同。量度整体的宽度，然后用直尺及水平仪把所测量到的尺寸纵横地画在墙上成为一个大方格。再将大方格分成9个方格，每个方格放1贴马赛克。

4. 准备瓷砖胶

准备好按照比例混合的瓷砖胶，用灰铲涂抹瓷砖胶，但是涂抹的面积不能超过放9贴马赛克的区域范围。首先要用有平滑边缘的灰铲抹平瓷砖胶，然后用有锯齿边缘的灰铲抹出一层均匀的锯齿形条纹。现在，马赛克就可似准备上墙铺贴。

5. 铺贴并固定

因为马赛克都是用网贴底的，因此可以直接地应用于已涂有瓷砖胶的墙面上。将马赛克垂直地铺贴。请注意:贴与贴之间的间隙一定要和每一贴的灰缝一致。

6. 加固

在每一贴砖定位后，用灰板轻拍马赛克表面，使之牢固贴在墙上。

7. 确保灰缝一致

在每一贴砖都固定之后，在开始放填缝料之前，砖与砖之间的间隙必须确定为统一的宽度。这样就要靠用小灰铲来调整灰缝。这是在铺贴马赛克过程中最需要耐性的一个过程，但在铺贴工作的过程中是最重要的环节。

8. 填缝剂

准备好所需的填缝剂。使用小灰铲，每次取小量的混合填缝剂，均匀涂于马赛克表面，小灰铲要对角地移动，先由下至上再由上至下，确保所有的灰缝能够完全填满并且没有多余的残留。

9. 清洁

在填缝剂干透之前，开始清洁马赛克表面。准备两个桶，一个装清洁剂，一个装干净水，首先在装清洁剂的桶内浸湿抹布，不用拧干，然后以打圈的方式拭擦马赛克表面，然后在第二个装有干净水的桶内浸湿海绵，再用海绵擦马赛克表面，擦去所有的残留物。最后，再一次用海绵擦表面直至干净为止。

Customer satisfaction depends on the selection of professional contractors skilled in the art of applying mosaic so that the value ofCAIHUA products find their full expression.

Tilers are therefore important and indeed indispensable partners in promoting the CAIHUA brand; their professionalism is crucial to our success. This section of the catalogue, a quick guide to the essential ingredients of a professional tiling job, is dedicated to them.

1. CHECKING THE MATERIAL

Before starting work, be careful to check the boxes containing the sheets of CAIHUA mosaic and ensure that there is sufficient material to complete the job. Every box indicates the item number, shade number, production batch number, and other details.

2. SKIMMING

This is a step that serves to render the substrate selected for tiling perfectly smooth, uniform and white (a substrate showing differences in color will spoil the appearance of the finished mosaic).

3. STARTING LINES

Draw lines on the surface of the substrate to aid correct positioning of the sheets. Lay three sheets out the floor side by side, so that the gap between the sheets is the same as the gap between the single tessera, and measure the overall width. Transfer this measurement both horizontally and vertically to the surface being covered and, using a straightedge and a spirit level, mark out a grid, the area will now be divided into a number of squares, each corresponding to nine sheets of mosaic.

4. PREPARING THE ADHESIVE

Prepare the adhesive, and spread over an area no larger than will be occupied by the first nine sheets, using the trowel. First apply a thick coat with the smooth edge of the tool, drawing the teeth across evenly and "combing" the adhesive to produce a uniformly ridged bed. The sheets can now be positioned.

5. LAYING AND FIXING

The sheets are back-mounted to a mesh that should be directly applied to the bed of adhesive. On walls, the thicker strands of mesh should be positioned vertically. Please note: the gap separating adjacent sheets must be the same as the gap between single tessera.

6.A FIRM BOND

With the sheets in place, tap the tessera home with a float so that the mesh beds firmly into the adhesive.

7.A PERFECT END RESULT

With all the sheets laid or fixed, and before the adhesive begins to set, the distance between tessera can be adjusted to ensure that all gaps are of uniform width. This is done by cutting through the mesh along the gap with a knife and edging the adjoining tessera marginally closer together or farther apart with the aid of a trowel. This is a step of the mosaic tiling procedure that calls for patience, but one that also adds considerable value to the finished job.

8. GROUTING

Make sure to use all of the grout. Using the small trowel, scoop the grout, a little at a time, onto the float and begin applying to the mosaic. Move the tool diagonally across the tessera, first from the bottom up and then squeegee downwards in the opposite direction, making certain that all of the joints are completely filled and that no excess remains.

9. CLEANING

Before the grout hardens, begin cleaning off the surface. Prepare two buckets of this solution: immerse the pad in the first, and without wringing swab the surface of the mosaic repeatedly with a circular motion. Next, immerse the sponge in the second bucket and wipe down the surface, removing all residual traces of grout. Finally, wipe down with the sponge, this time using clean water to remove any smears, leaving the mosaic sparklingly clean.

本型录产品颜色因印刷及摄影之故，所记录的产品图片可能与实物有所差异；定货时请确认实物样品。

所有产品以实物样品为准，如有更改，恕不另行通知。 版权所有，翻版必究。 最终解释权归“佛山市石湾裕龙陶瓷有限公司”所有。